

TRDP-UDP

Datasheet

Email: yacer@yacer.cn

Web: www.yacer.com.cn

Foreword

Notational Conventions

The following categorized signal words with defined meaning might appear in the manual.







Signal Words	Meaning
 DANGER	Indicates a high potential hazard which, if not avoided, will result in death or serious injury.
 CAUTION	Indicates a potential risk which, if not avoided, could result in property damage, data loss, lower performance, or unpredictable result.
 ANTISTATIC	Indicates static sensitive equipment.
 DANGER! ELECTRIC SHOCK	Indicates High voltage danger.
 TIPS	Provides methods to help you solve a problem or save you time.
 NOTE	Provides additional information as the emphasis and supplement to the text.

Table of Contents

Foreword	I
1 Overview	4
1.1 Introduction	4
1.2 Applications	4
1.3 Features	4
1.4 Order Information	4
1.5 Technical Specifications	5
1.6 Mechanical Dimensions	6
2 Hardware and Physical Interface	7
2.1 Appearance	7
2.2 LED Indicators	7
2.3 X1: 2x10 2.0mm pitch connector	7
2.4 X2: 2x10 2.0mm pitch connector	8
3 Working State and Initialization	10
3.1 Working State	10
3.2 Module Initialization Mode	10
3.3 Host initialization programming interface	10
4 yacer-DMS Configuration Management	11
4.1 Get Configuration Management software yacer-DMS	11
4.2 Connect Configuration Computer to TRDP-UDP	11
4.2.1 Configuration via Ethernet port	11
4.2.2 Configuration via DMS-UART (X3) interface	11
4.3 Main Window of yacer-DMS	12
4.4 Statistical Report	13
4.4.1 Control Panel	13
4.4.2 Receive/Transmit Indication Panel	13
4.4.3 Information Panel	13
4.5 Configure Device	14
4.6 System Configuration	15
4.6.1 Initialization Mode	15
4.6.2 Serial Configuration	15
4.6.3 CAN Baudrate	16
4.6.4 TRDP Work Mode	16
4.6.5 TRDP Forward Interface	16
4.6.6 DMS of TRDP Ethernet Interface	16
4.7 UDP configuration	17
4.8 Ethernet Interface	17
4.9 TRDP Receive Configuration	17
4.10 TRDP Send Configuration	18
4.11 Firmware Version Upgrade	18
4.11.1 Start Upgrade	18

4.11.2 Select Version File	19
4.11.3 Complete Upgrade	19
4.11.4 Re-Power Up to Take Effect	20
4.11.5 Confirm Upgrade	20
4.12 Reboot Device	21
5 Hardware Development	22
5.1 Ethernet Interface Development	22
5.1.1 M12 Connector	22
5.1.2 Reference Circuit	22
6 Software Development	23

1 Overview

1.1 Introduction

The Yacer dual redundant TRDP embedded module, provides two TRDP redundant 100M Ethernet interfaces, one TCP/IP Ethernet interface, one UART interface and one CAN interface to implement protocol conversion between TRDP and UDP, serial port or CAN bus.

35x45mm small size, 2.0mm pin connector. +3.3V power supply, low power consumption. Industrial grade wide temperature, suitable for embedded applications.

1.2 Applications

- Protocol conversion between TRDP and UDP ;
- Protocol conversion between TRDP and serial port;
- Protocol conversion between TRDP and CAN interface;
- Train Control and Management System (TCMS);
- Train Communication Network (TCN);
- Embedded development and application.

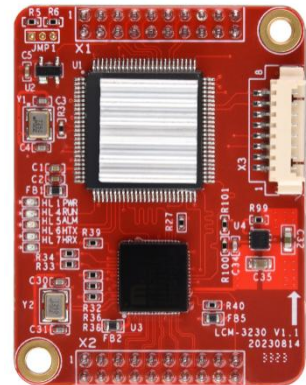

1.3 Features

- Two 100M full-duplex Ethernet interfaces, supports TRDP protocol;
- One 100M adaptive Ethernet interface, supports TCP/IP protocol;
- One UART serial port;
- One CAN bus interface;
- Support TRDP PD acquisition function
- +3.3V power supply, low power consumption;
- Small size, industrial wide temperature.

1.4 Order Information

Product Model	Ethernet Interface	Serial Port	CAN
TRDP-UDP-320	3 x 10/100M PHY	1 x UART	1 x CAN

1.5 Technical Specifications

Item	Parameters	Details
TRDP Ethernet Interface	Number	2 x 100M PHY
	Rate	100 Mbps full-duplex
	Protocol	TRDP
TCP/IP Ethernet Interface	Number	1 x 100M PHY
	Rate	100 Mbps adaptive
	Protocol	TCP/IP
UART Interface	Level Standard	3.3V LVCMOS
	Duplex Mode	Full-duplex
	Baud Rate	≤ 921.6 Kbps
CAN Interface	Level Standard	3.3V LVCMOS
	Working Mode	CAN 2.0A、CAN2.0B, ISO 11898
	Baud Rate	≤ 1 Mbps
Configuration Management	Configuration Tool	yacer-DMS configuration management software
	Console Interface	Ethernet Interface Dedicated DMS-UART interface (with Yacer ' s DMS-UART-8P configuration cable)
Power Requirements	Input Voltage	+3.3 VDC
	Power Consumption	< 2 W
Mechanical Characteristics	Dimensions	35 x 45 mm
	Weight	25g
Operating Environment	Operating temperature	-40 ~ +85℃
	Storage temperature	-40 ~ +85℃
	Operating humidity	5 ~ 95% RH (no condensation)

1.6 Mechanical Dimensions

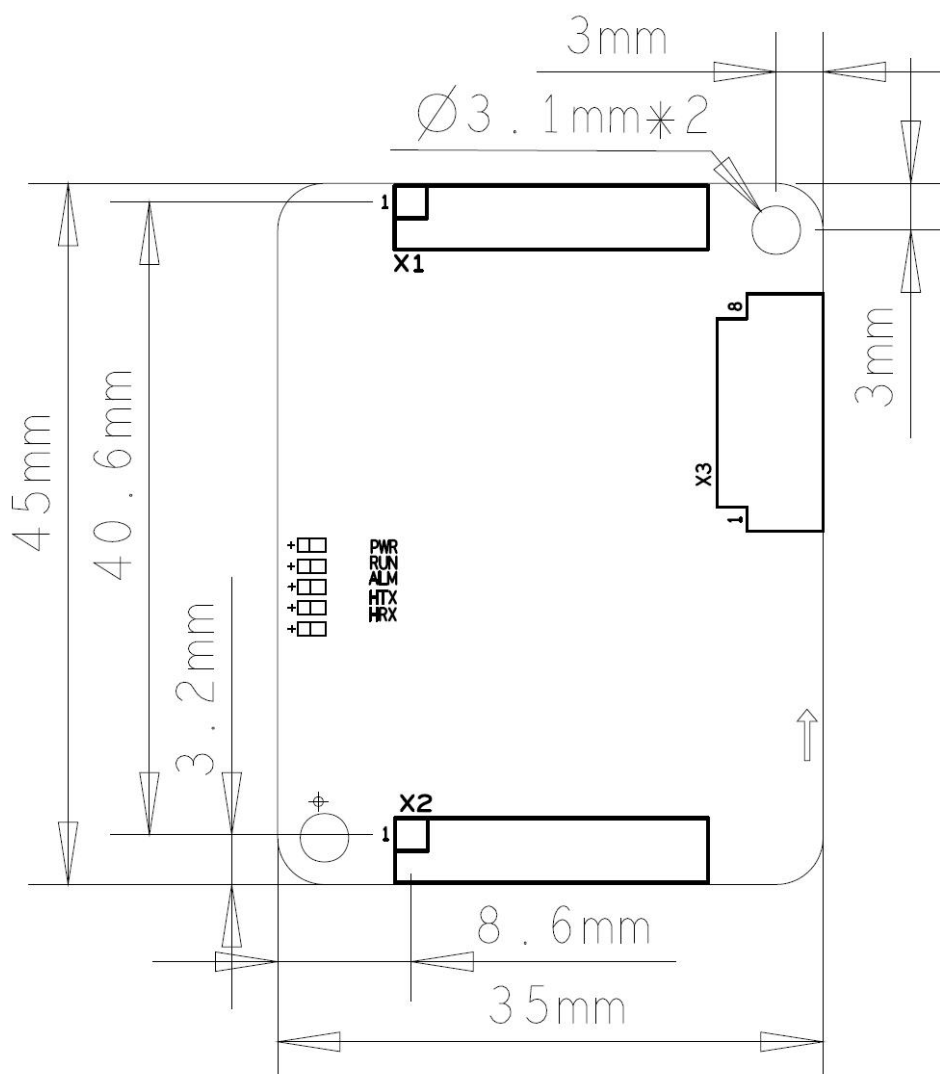

2 Hardware and Physical Interface

2.1 Appearance

The top and bottom view of TRDP-UDP are as follows, and the signals are drawn out through connector X1 and X2.

X3 is configuration interface used to connect the DMS-UART-8P configuration cable and configure it online through the management computer's USB interface.

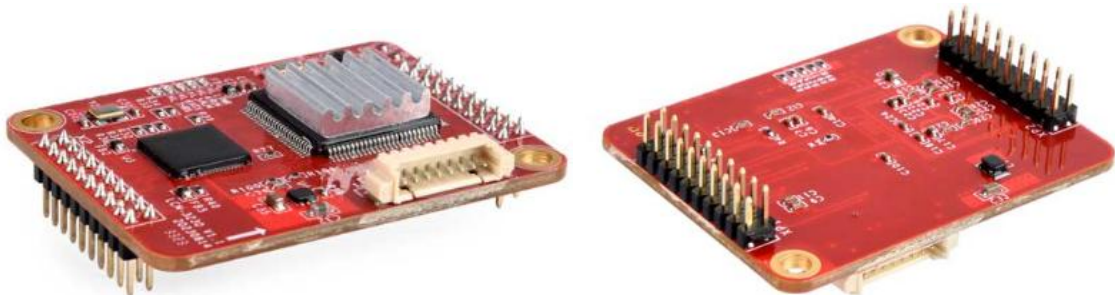

2.2 LED Indicators

LED	Description
RUN	Running indicator, Green light flashes during normal operation
ARM	Alarm indicator <ul style="list-style-type: none"> Initialization phase blinking: waiting for the host computer configuration command Normal operation status off: the device is working normally Normal operation status on: device failure
PWR	Power indicator
HTX	CAN, UART, UDP transmit indicator
HRX	CAN, UART, UDP receive indicator

2.3 X1: 2x10 2.0mm pitch connector

Pin	Signal	Type	Description
1	GND		Ground
2	GND		Ground
3	VCC3V3	I	Power input, +3.3 VDC
4	VCC3V3	I	Power input, +3.3 VDC

Pin	Signal	Type	Description
5	RESET_IN	I	Module reset input, active low. Power-On Reset supported, Pin can be suspended.
6	LED_RUN	O	System operation indication, drive LED negative
7	LED_ALARM	O	System alarm indication, drive LED negative
8	LED_TX	O	Serial transmission Indication, drive LED negative
9	LED_RX	O	Serial reception Indication, drive LED negative
10	NC		Must be left suspended
11	UART_TxD	O	Serial port data transmission
12	UART_RxD	I	Serial port data reception
13	CAN_TX	O	CAN interface data transmission
14	CAN_RX	I	CAN interface data reception
15	NC		Must be left suspended
16	NC		Must be left suspended
17	NC		Must be left suspended
18	NC		Must be left suspended
19	GND		Ground
20	GND		Ground

2.4 X2: 2x10 2.0mm pitch connector

Pin	Signal	Type	Description
1	GND		Ground
2	GND		Ground
3	TRDP0_RX+		Rx+ for TRDP0 Ethernet PHY interface, external network transformer required
4	TRDP0_RX-		Rx- for TRDP0 Ethernet PHY interface, external network transformer required
5	TRDP0_TX+		Tx+ for TRDP0 Ethernet PHY interface, external network transformer required
6	TRDP0_TX-		Tx- for TRDP0 Ethernet PHY interface, external network transformer required
7	TRDP1_RX+		Rx+ for TRDP1 Ethernet PHY interface, external network transformer required
8	TRDP1_RX-		Rx- for TRDP1 Ethernet PHY interface, external network transformer required
9	TRDP1_TX+		Tx+ for TRDP1 Ethernet PHY interface, external network transformer required
10	TRDP1_TX-		Tx- for TRDP1 Ethernet PHY interface, external network transformer required
11	TCPIP_RX+		Rx+ for TCPIP Ethernet PHY interface, external network transformer required

Pin	Signal	Type	Description
12	TCPIP_RX-		Rx- for TCPIP Ethernet PHY interface, external network transformer required
13	TCPIP_TX+		Tx+ for TCPIP Ethernet PHY interface, external network transformer required
14	TCPIP_TX-		Tx- for TCPIP Ethernet PHY interface, external network transformer required
15	GND		Ground
16	GND		Ground
17	LED_TRDP0	O	Link/Act indication for TRDP0 Ethernet port, drive LED negative
18	LED_TRDP1	O	Link/Act indication for TRDP1 Ethernet port, drive LED negative
19	LED_TCPIP	O	Link/Act indication for TCPIP Ethernet port, drive LED negative
20	TRDP_TRX_LED	O	TRDP transmit and receive indicator, drive LED negative

3 Working State and Initialization

3.1 Working State

The TRDP-UDP module has two working states:

- Initialization state: When the module is powered up, it enters the initialization state first, receives or loads the configuration, and performs the system initialization operation.
- Running state: After the module is initialized, it enters the running state and works according to the configuration.

3.2 Module Initialization Mode

The TRDP-UDP module has two initialization methods:

- Host initialization: After the module is powered on, it obtains configuration data from the host through messages and initializes the system. The default initialization mode is Host.
- Local initialization: After the module is powered on, it loads the configuration data from the module's onboard FLASH for initialization.

3.3 Host initialization programming interface

Reference document "THCP Protocol Programming Manual".

4 yacer-DMS Configuration Management

4.1 Get Configuration Management software yacer-DMS

Users can obtain the compressed package yacer-DMS.zip of configuration management software through the following ways:

- “Softwares” directory of TRDP-UDP accompanied U-Disk;
- Official website of Yacer (<http://www.yacer.com.cn>) Software channel.

The yacer-DMS is an installation free application software, unzip yacer-DMS.zip, enter the working directory and double click the file yacer-DMS.exe to run.

4.2 Connect Configuration Computer to TRDP-UDP

4.2.1 Configuration via Ethernet port

Connect the management computer with TCP/IP Ethernet interface of TRDP-UDP through network cable, and run yacer-DMS configuration management software on the computer to configure the parameters and monitor running status of TRDP-UDP.

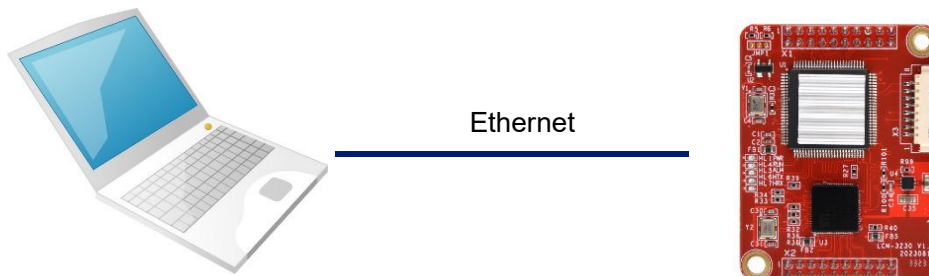

4.2.2 Configuration via DMS-UART (X3) interface

If the TRDP-UDP's Ethernet port is occupied, the DMS-UART-8P configuration cable can be used to connect the TRDP-UDP's DMS-UART interface to the computer's USB port.

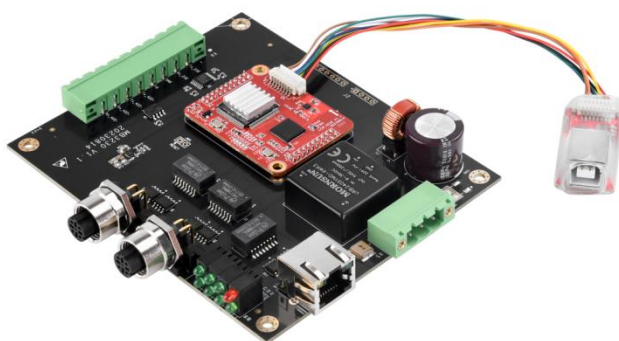

When DMS-UART-8P configuration cable is connected to the management computer USB interface, the computer will add a USB simulation serial port.

Click the “Interface” button on the toolbar to pop up the “Host Interface for DMS” configuration dialog. Enter the “Serial” page, select the serial port of the computer connected to TRDP-UDP from the drop-down list, and click “Open Serial” button.

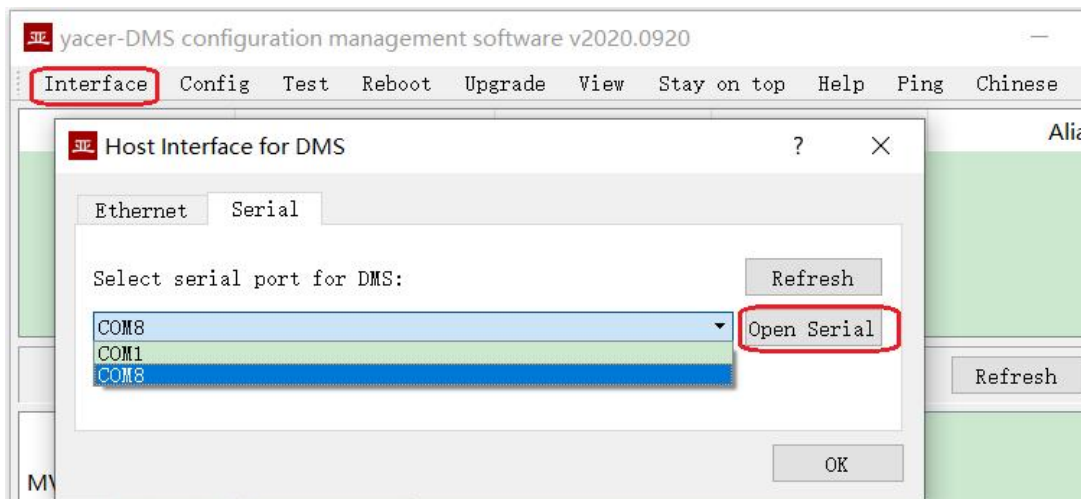

If the serial port is successfully opened, the status is as follows:

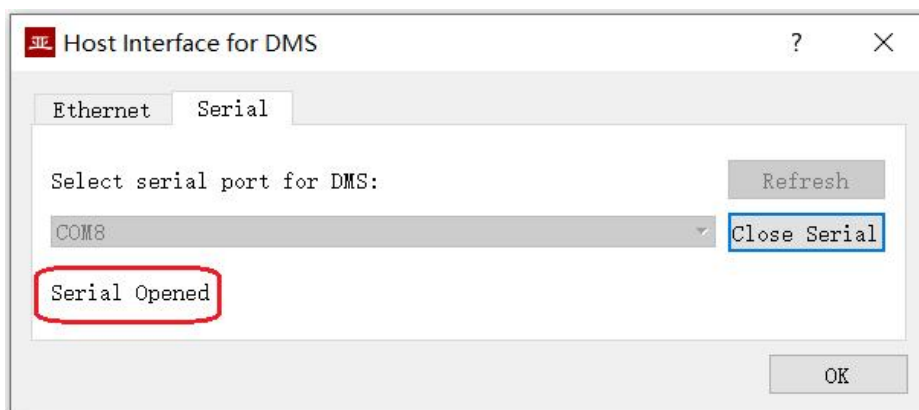

4.3 Main Window of yacer-DMS

The following figure is the main interface of the configuration management software, which can be divided into three parts:

- Toolbar: Functional operation buttons;
- Device List: Displaying the basic information and operation status of online devices;
- Statistical Report: Displaying the receive/transmit indication & statistics, and device details.

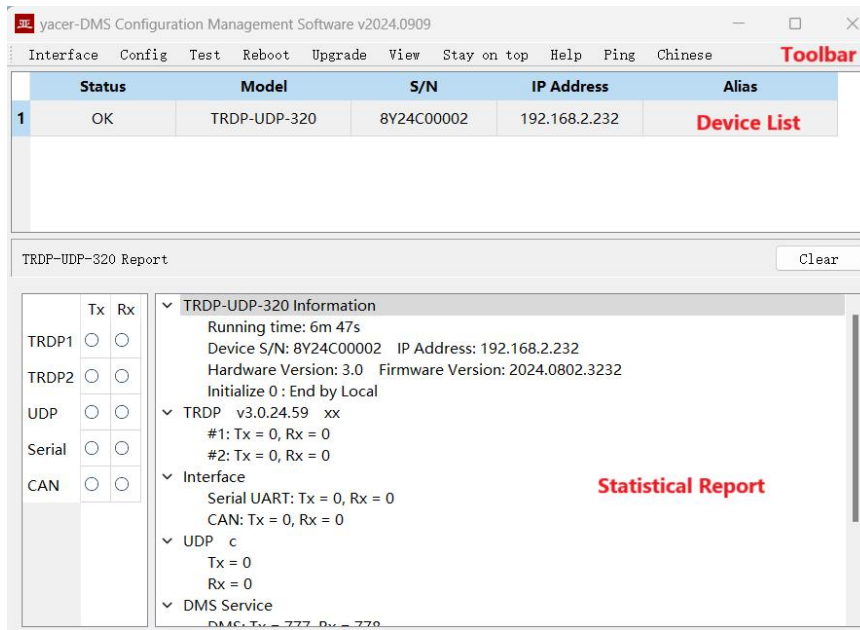

4.4 Statistical Report

The statistical report has three panels: control panel, receive/transmit indication panel and information panel.

4.4.1 Control Panel

Statistical reports are refreshed once per second, and the statistics can be cleared by clicking the "Clear" button.

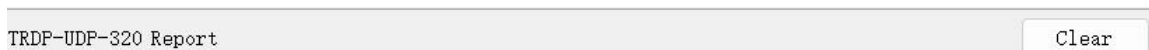

4.4.2 Receive/Transmit Indication Panel

- Tx: The interface sends a frame of data, corresponding Tx indicator blinks once;
- Rx: The interface receives a frame of data, corresponding Rx indicator blinks once.

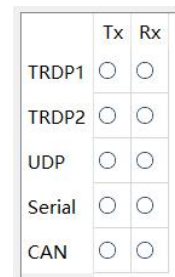

4.4.3 Information Panel

Display the following contents:

- Device information: Running time, S/N, IP address and Version number;
- TRDP: TRDP protocol transceiver statistics;

- Host Interface: CAN and serial port receive/transmit statistics;
- UDP: UDP transceiver statistics;
- DMS Service: DMS message receive/transmit statistics.

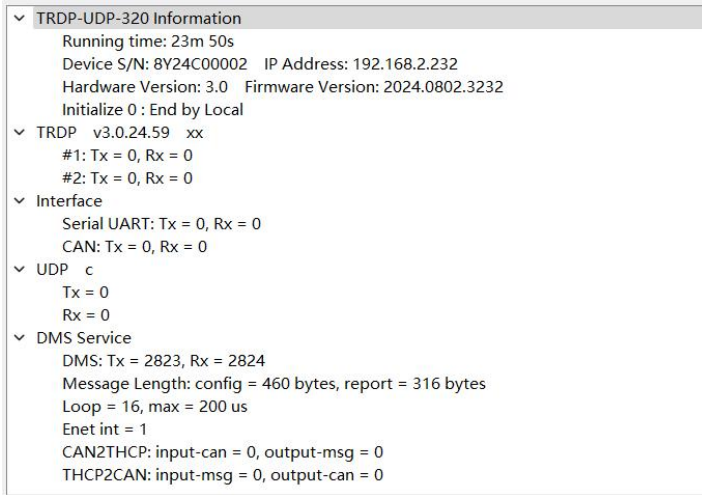

4.5 Configure Device

Click the 'Config' button on the toolbar or double-click the selected device in the device list, yacer-DMS pops up the configuration dialog. According to the interface and function, the dialog divides the configuration items into several configuration pages.

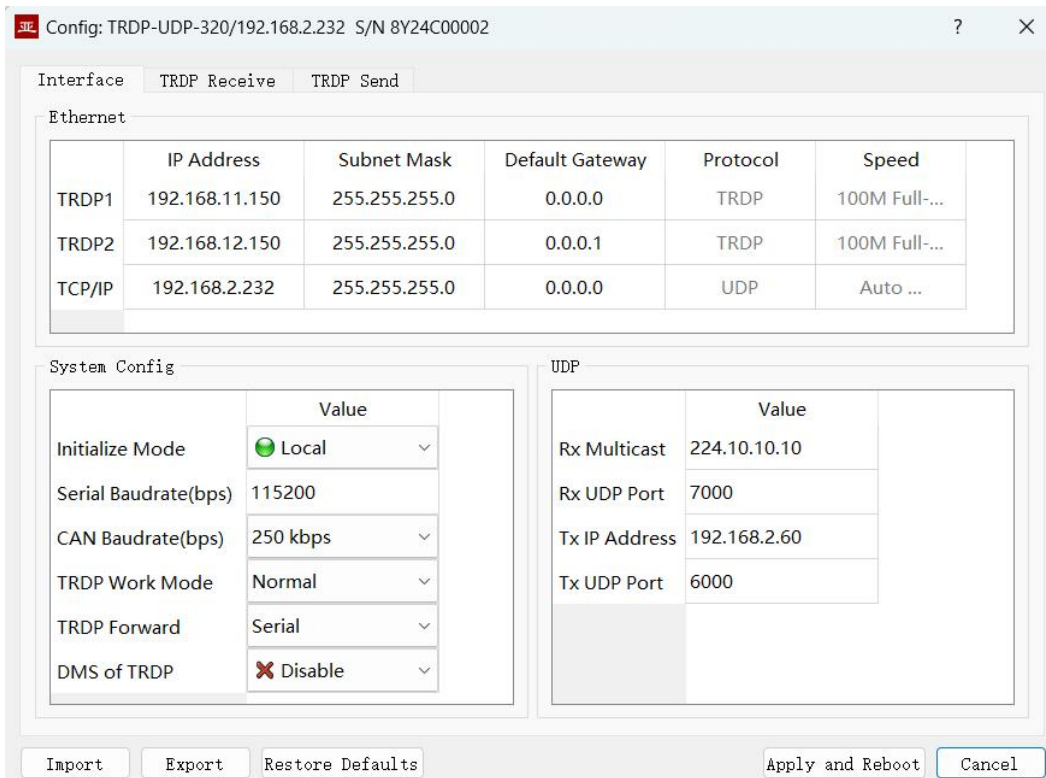

The bottom of the dialog box includes the following operation buttons:

Button	Function
<input type="button" value="Import"/>	Open the configuration file, read the configuration parameters refresh the configuration dialog
<input type="button" value="Export"/>	Export configuration parameters from the configuration dialog to a file for saving
<input type="button" value="Restore Defaults"/>	Refresh the configuration dialog with the factory paramters
<input type="button" value="Apply and Reboot"/>	Write the configuration parameters in the dialog to the deivce, and restart the device to make the configuration take effect
<input type="button" value="Cancel"/>	Cancel current configuration operation

4.6 System Configuration

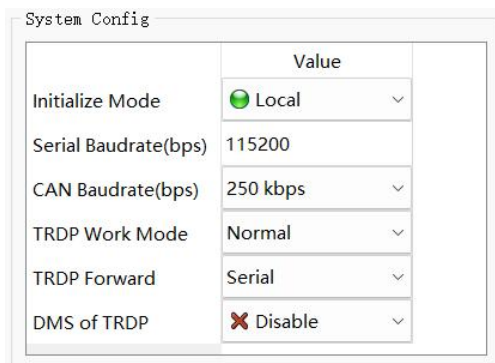

4.6.1 Initialization Mode

Configure the initialization mode for TRDP-UDP module, and the factory default value is Host.

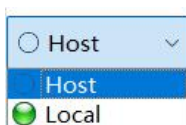

4.6.2 Serial Configuration

Configure the baud rate for serial port. Other serial port parameters are: 8-bit data bit, 1-bit stop bit, and no parity.



4.6.3 CAN Baudrate

Configure the baud rate for CAN interface.

CAN Baudrate(bps)

4.6.4 TRDP Work Mode

Configure TRDP working mode, it can be configured in Local initialization mode. By default, the TRDP working mode is normal.

In the acquisition mode, the TRDP-UDP module will collect all the TRDP PD data whose destination IP address is multicast or broadcast on the network in real time and forward it to the host.

TRDP Work Mode

TRDP Forward

Acquisition

4.6.5 TRDP Forward Interface

In Local initialization mode, this configuration is valid.

In Host mode, it indicates the current working interface between host and TRDP-UDP module, and can't be changed by configuration.

TRDP Forward

DMS of TRDP

CAN

Ethernet

4.6.6 DMS of TRDP Ethernet Interface

Configure TRDP Ethernet interface to enable DMS function, and TRDP interface doesn't enable DMS function by default.

DMS of TRDP

Enable

Disable

4.7 UDP configuration

UDP	
	Value
Rx Multicast	224.10.10.10
Rx UDP Port	7000
Tx IP Address	192.168.2.60
Tx UDP Port	6000

Configure the IP and UDP ports for communication between the host computer and TRDP-UDP module, including the following:

- Receive multicast address: When the host sends messages to TRDP-UDP, use this multicast address as the destination IP.
- Receive UDP port: When the host sends messages to TRDP-UDP, use this port as the UDP destination port.
- Destination IP address: When TRDP-UDP sends messages to the host, use this IP address as the destination IP.
- Destination UDP Port: When TRDP-UDP sends messages to the host, use this port as the UDP destination port.

4.8 Ethernet Interface

TRDP0 and TRDP1 are redundant TRDP network ports, which are forced to work in 100M full-duplex mode.

The TCP/IP network port works in adaptive mode and uses UDP to communicate with the host computer.

Interface	TRDP Receive	TRDP Send			
Ethernet					
	IP Address	Subnet Mask	Default Gateway	Protocol	Speed
TRDP1	192.168.11.150	255.255.255.0	0.0.0.0	TRDP	100M Full-...
TRDP2	192.168.12.150	255.255.255.0	0.0.0.1	TRDP	100M Full-...
TCP/IP	192.168.2.232	255.255.255.0	0.0.0.0	UDP	Auto ...

4.9 TRDP Receive Configuration

This page can configure up to 16 TRDP subscription PD entries and supports multicast reception.

The subscribed TRDP PD data is forwarded to the host computer through the UART interface, CAN interface, or UDP Ethernet interface.

Interface				
TRDP Receive				
TRDP Send				
TRDP PD Subscribe				
	TRDP Netif	TRDP Rx COMID	TRDP Rx Multicast	
1	TRDP1	4	224.1.1.5	
2	TRDP1	3	224.1.1.5	
3	TRDP2	14	224.1.1.6	
4	TRDP2	13	224.1.1.6	
5	Disable	0	0.0.0.0	

4.10 TRDP Send Configuration

This page can configure up to 16 TRDP Publish PD entries.

TRDP-UDP receives data from the host computer through UART interface, CAN interface, or Ethernet UDP interface, refreshes the PD buffer of TRDP protocol, and then periodically sends PD data according to the configuration. Its destination address can be unicast, multicast, or broadcast.

Interface				
TRDP Receive				
TRDP Send				
TRDP PD Publish				
	TRDP Netif	TRDP Tx COMID	TRDP Tx Interval(ms)	TRDP Tx Destination IP
1	TRDP1	5	300	224.1.2.7
2	TRDP1	6	3000	224.1.3.9
3	TRDP2	15	300	224.1.4.7
4	TRDP2	16	300	224.1.5.9
5	Disable	0	0	0.0.0.0

4.11 Firmware Version Upgrade

4.11.1 Start Upgrade

Click the “Upgrade” button on the toolbar to pop up the version upgrade dialog, and then click the “Start” button.

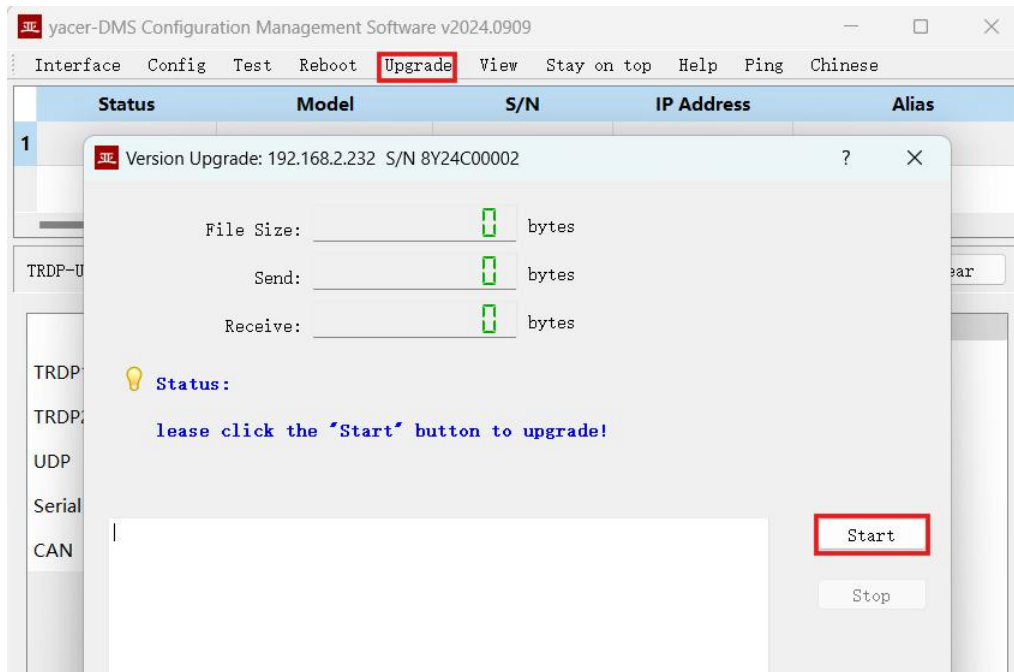

4.11.2 Select Version File

Pop up the “Select version file” dialog, and find the firmware version file to be updated, select it and click "Open".

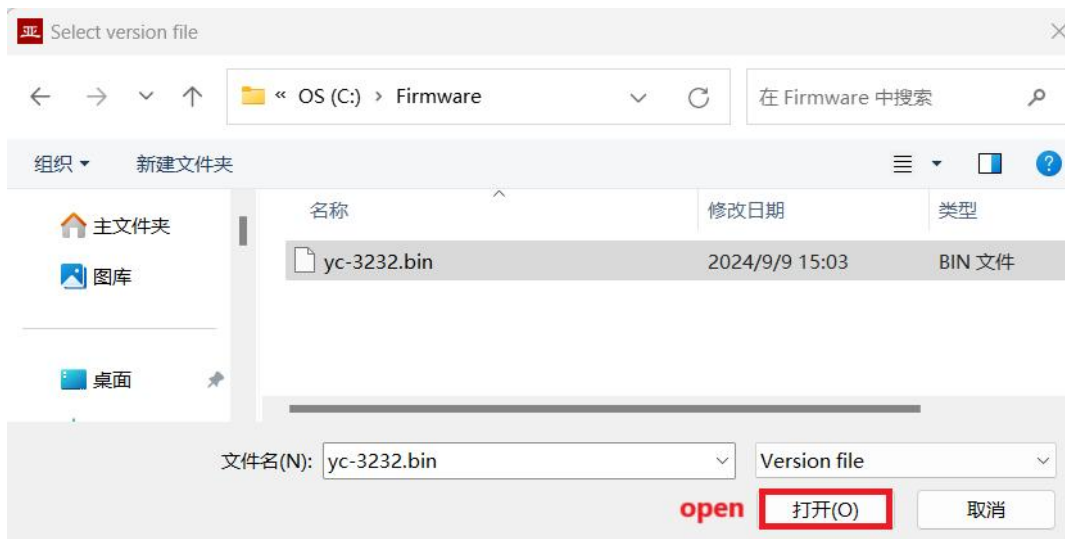

4.11.3 Complete Upgrade

When the page displays “Version upgrade complete” status, it indicates that the version upgrade is completed.

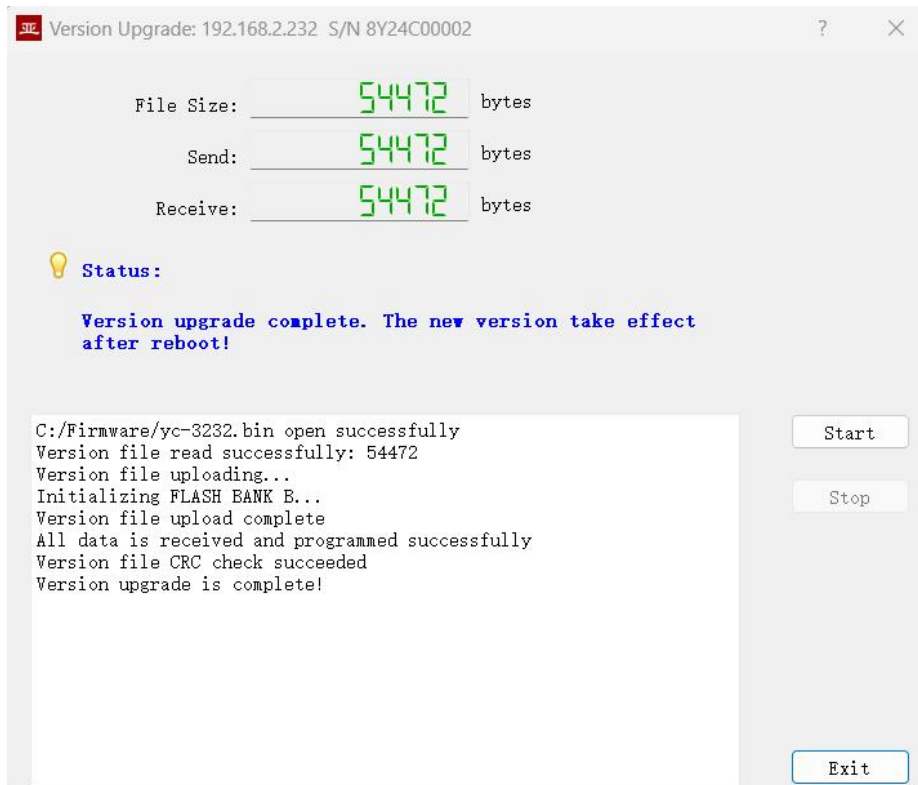

4.11.4 Re-Power Up to Take Effect

Re-power the device and wait a minute or so for the new version to boot up and take effect.



NOTE: The device cannot be powered down during the waiting period.

4.11.5 Confirm Upgrade

After the upgrade is completed, power up the device again, observe the version information in the statistical report, and determine whether the new version is successfully updated by the version date.

- ▼ TRDP-UDP-320 Information
 - Running time: 3h 29m 41s
 - Device S/N: 8Y24C00002 IP Address: 192.168.2.232
 - Hardware Version: 3.0 Firmware Version: 2024.0802.3232
 - Initialize 0 : End by Local

4.12 Reboot Device

Click the “Reboot” button on the toolbar to pop up the device reboot dialog, and then click the “Reboot” button to reboot the device.

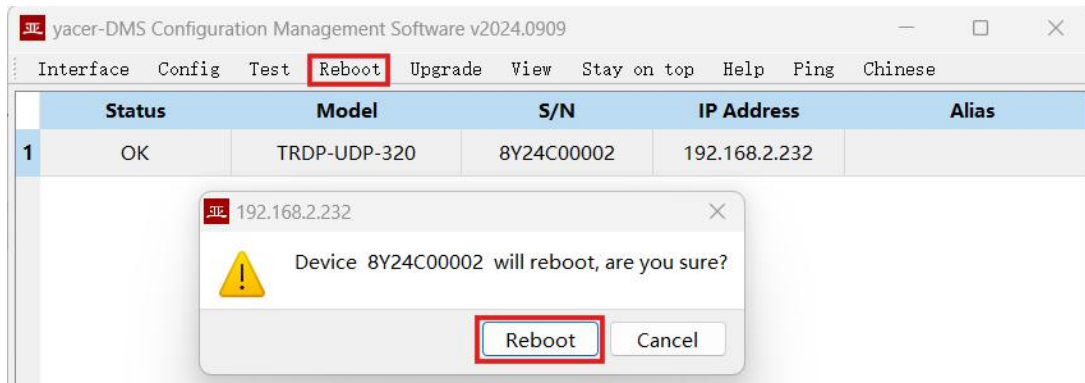

5 Hardware Development

5.1 Ethernet Interface Development

5.1.1 M12 Connector

The train Ethernet interface uses the M12 connector (D-type coded hole) of IEC 61706-2-101 standard. The socket front view and pins are defined as follows:

Pin	Description
1	TD +
2	RD +
3	TD -
4	RD -

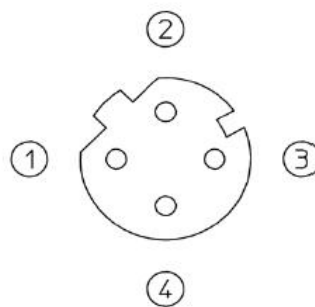

5.1.2 Reference Circuit

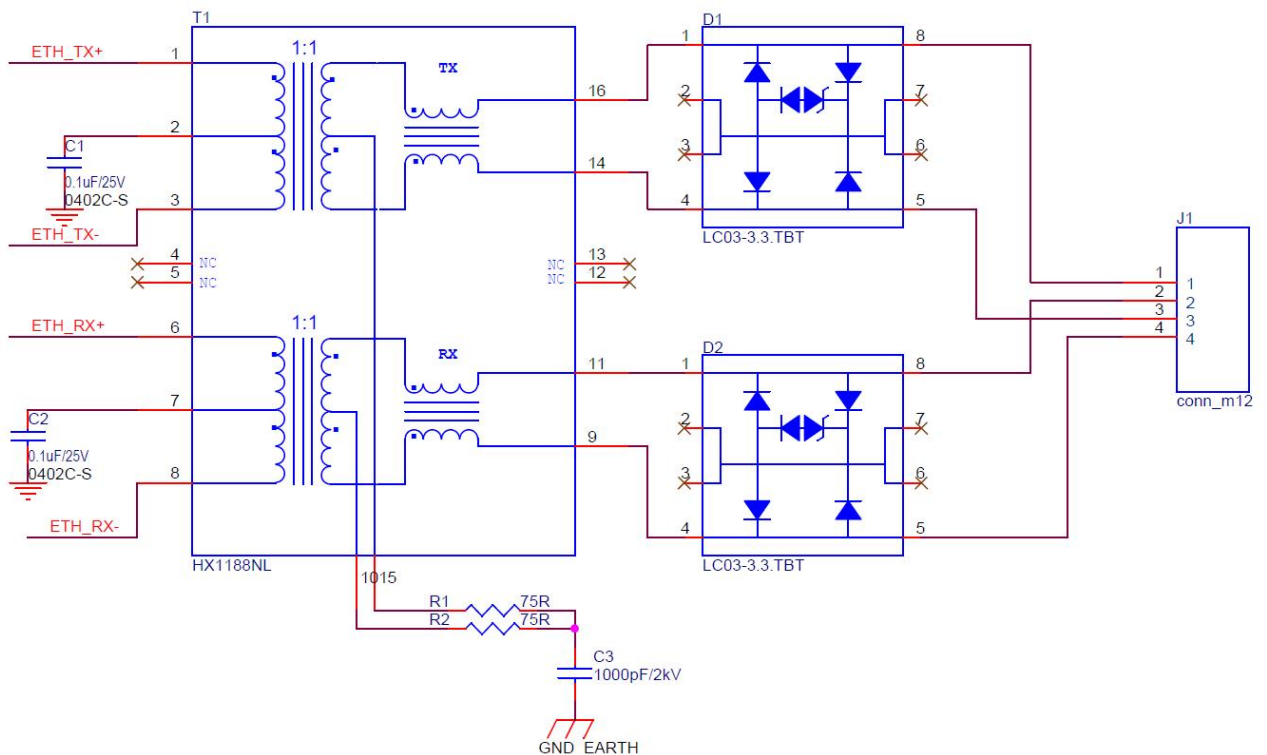

6 Software Development

Reference:

- *THCP Protocol Programming Manual*

UART-PPP protocol implementation C code:

- `yacer_uart_ppp.c`

THCP references C code:

- `thcp_inc.h`
- `thcp_canInc.h`
- `thcp_can.c`: The THCP protocol CAN translates the code

About the Manual

- The manual is for reference only. If there is inconsistency between the manual and the actual product, the actual product shall prevail.
- We are not liable for any loss caused by the operations that do not comply with the manual.
- All the designs and software are subject to change without prior written notice. The product updates might cause some differences between the actual product and the manual. Please contact the customer service for the latest program and supplementary documentation.
- There still might be deviation in technical data, functions and operations description, or errors in print. If there is any doubt or dispute, we reserve the right of final explanation.
- Upgrade the reader software or try other mainstream reader software if the manual (in PDF format) cannot be opened.
- Please visit our website, contact the supplier or customer service if there is any problem occurring when using the device.
- If there is any uncertainty or controversy, we reserve the right of final explanation.