

MVB-UDP

Datasheet

Email: yacer@yacer.cn

Web: www.yacer.com.cn

Foreword

Notational Conventions

The following categorized signal words with defined meaning might appear in the manual.







Signal Words	Meaning
 DANGER	Indicates a high potential hazard which, if not avoided, will result in death or serious injury.
 CAUTION	Indicates a potential risk which, if not avoided, could result in property damage, data loss, lower performance, or unpredictable result.
 ANTISTATIC	Indicates static sensitive equipment.
 DANGER! ELECTRIC SHOCK	Indicates High voltage danger.
 TIPS	Provides methods to help you solve a problem or save you time.
 NOTE	Provides additional information as the emphasis and supplement to the text.

Table of Contents

Foreword	I
1 Overview	4
1.1 Introduction	4
1.2 Features	4
1.3 Applications	4
1.4 Order Information	5
1.5 Technical Specifications	5
1.6 Mechanical Dimension Drawing	6
2 Hardware and Physical Interfaces	7
2.1 Appearance	7
2.2 LED Indicators	7
2.3 Extended Pin Definition	8
2.3.1 X1: 1x13 2.54mm pitch connector	8
2.3.2 X2: 1x13 2.54mm pitch connector	8
3 Working State and Initialization	10
3.1 Working State	10
3.2 Module Initialization Method	10
3.3 Host Initialization Programming Interface	10
4 Building Configuration Environment	11
4.1 Connect Management Computer to MVB-UDP	11
4.1.1 Configure with special DMS-UART interface	11
4.1.2 Configuration with Ethernet interface	11
4.2 Get Configuration Management Software yacer-DMS	12
4.3 Run yacer-DMS Software	12
4.4 Select & Open Configuration Serial Port	12
4.5 Main Window of yacer-DMS	13
4.6 Statistical Report	13
4.6.1 Control panel	13
4.6.2 Receive & Transmit indication panel	14
4.6.3 Information panel	14
4.7 Configure Device	14
5 Function and Configuration	16
5.1 System Configuration	16
5.1.1 Initialization Method	16
5.1.2 Serial Port Baud Rate	16
5.1.3 MVB Operating Mode	16
5.1.4 MVB forwarding interface	17
5.2 Ethernet Interface Configuration	17
5.3 MVB Configuration	18
5.3.1 Device address	18
5.3.2 Media type	18

5.3.3 Line type	19
5.3.4 PD port configuration table	19
5.4 Firmware Version Upgrade	19
5.4.1 Start upgrade	19
5.4.2 Select version file	20
5.4.3 Complete upgrade	20
5.4.4 Confirm upgrade	21
5.5 Reboot Device	21
6 Hardware Development	22
7 Software Development	22

1 Overview

1.1 Introduction

The Yacer MVB-UDP embedded slave network card module, providing a set of full-featured MVB redundant interfaces, one 100M Ethernet PHY interface, and one UART extended serial port to realize the protocol conversion between MVB, UDP and serial port.

46.5 × 48mm tiny size, 2.54mm pin connector. + 5V power supply, low power consumption. Industrial wide temperature, suitable for embedded applications.

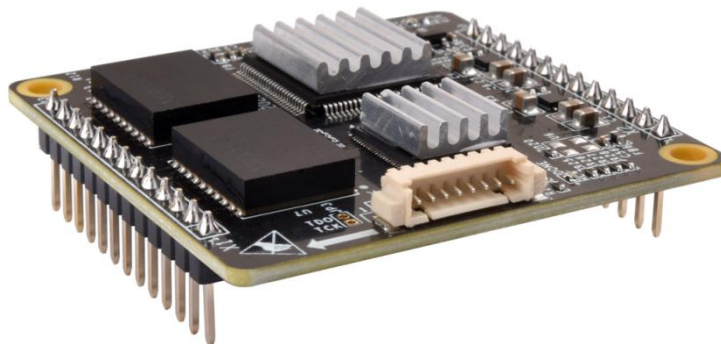

1.2 Features

- One 10/100M Ethernet PHY interface;
- One UART extended serial port;
- Full feature MVB redundant interface, Support EMD, ESD+ interface, IEC61375 compliant;
- Supports MVB slave protocol, multiple PD source and sink ports;
- Supports PD data acquisition function of MVB-bus;
- +5V power supply, low power consumption;
- Small size, Industrial wide temperature.

1.3 Applications

- Protocol conversion between MVB and Ethernet;
- Protocol conversion between MVB and serial port;
- MVB bus PD data monitoring;
- Train Control and Management System (TCMS);
- Train Communication Network (TCN);
- Embedded development and application.

1.4 Order Information

Model	Description
MVB-UDP-300	1 x dual redundancy MVB + 1 x Ethernet PHY + 1 x UART

1.5 Technical Specifications

Item	Parameters	Details
MVB Interface	Media support	EMD, ESD+
	Device class	Class 1
	Device capabilities	Device_Status, Process_Data(PD)
	Number of PD ports	32
	Isolation	2.5 kVrms
Ethernet Interface	Number	1 x 10/100M PHY
	Rate	10/100 Mbps, supports MDI/MDIX adaptive
	Protocol	UDP
	Programming interface	UDP Server, UDP Client, supports unicast / multicast / broadcast
Extended Serial Port	Level standard	3.3V LVCMOS
	Working mode	Asynchronous UART
	Baud rate	≤ 921.6 Kbps
Configuration Management	Configuration interface	Special DMS-UART interface (by DMS-UART-8P cable) Ethernet interface
	Configuration tool	yacer-DMS configuration management software
Power Requirements	Power supply	+5 VDC
	Power consumption	< 2W
Mechanical	Connector	Two 2.54mm pitch 13-pin single-row male connectors

Item	Parameters	Details
Characteristics	Dimensions	46.5 x 48 mm
	Weight	15 g
Operating Environment	Operating temperature	-40 ~ +85°C
	Storage temperature	-40 ~ +85°C
	Operating humidity	5 ~ 95% RH (no condensation)



NOTE: If you need to support more MVB PD ports, please contact the manufacturer.

1.6 Mechanical Dimension Drawing

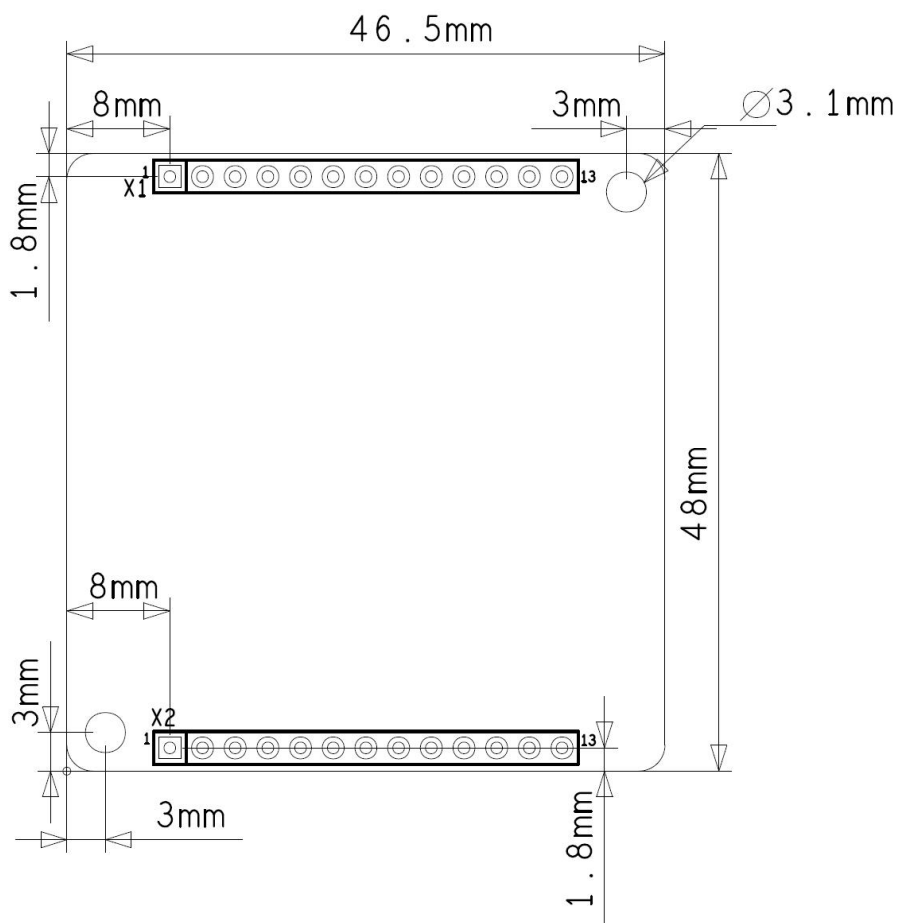

2 Hardware and Physical Interfaces

2.1 Appearance

The top and bottom view of MVB-UDP are as follows, and the signals are drawn out through connector X1 and X2.

X3 is the configuration interface used to connect the DMS-UART-8P configuration cable and configure it online through the management computer's USB interface.

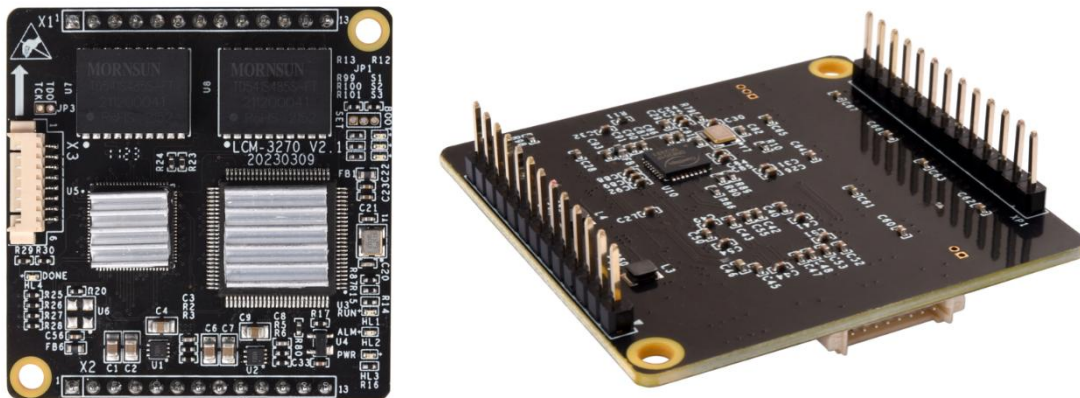

2.2 LED Indicators

Item	Description
RUN	Running indicator, green light flashes during normal operation
ALM	Alarm indicator <ul style="list-style-type: none"> Initialization phase blinking: waiting for the host computer configuration command Normal operation status off: the device is working normally Normal operation status on: device failure
PWR	Power indicator, always on after power on

2.3 Extended Pin Definition

2.3.1 X1: 1x13 2.54mm pitch connector

Pin	Name	Type	Description
1	MVB_A_5V_OUT	O	MVB interface Line A power output
2	MVB_A_TxD +	O	MVB interface Line A transmit positive (+)
3	MVB_A_TxD -	O	MVB interface Line A transmit negative (-)
4	MVB_A_RxD +	I	MVB interface Line A receive positive (+)
5	MVB_A_RxD -	I	MVB interface Line A receive negative (-)
6	MVB_A_GND		MVB interface Line A ground
7	NC		Standby, this pin must be left floating
8	MVB_B_5V_OUT	O	MVB interface Line B power output
9	MVB_B_TxD +	O	MVB interface Line B transmit positive (+)
10	MVB_B_TxD -	O	MVB interface Line B transmit negative (-)
11	MVB_B_RxD +	I	MVB interface Line B receive positive (+)
12	MVB_B_RxD -	I	MVB interface Line B receive negative (-)
13	MVB_B_GND		MVB interface Line B ground



NOTE: User must short connect TxD+ and RxD+, TxD- and RxD- of MVB.

2.3.2 X2: 1x13 2.54mm pitch connector

Pin	Name	Type	Description
1	GND		Logical Ground
2	ETH_RX+		Rx+ for Ethernet PHY interface, external network transformer required
3	ETH_RX-		Rx- for Ethernet PHY interface, external network transformer required

Pin	Name	Type	Description
4	ETH_TX+		Tx+ for Ethernet PHY interface, external network transformer required
5	ETH_TX-		Tx- for Ethernet PHY interface, external network transformer required
6	ETH_LED	O	Ethernet Link/Act indication, drive LED positive
7	NC		Standby, this pin must be left floating
8	UART_RxD	I	Serial port data receive
9	UART_TxD	O	Serial port data transmit
10	RESET_IN	I	Module reset, active low. Power-On Reset supported, Pin can be suspended.
11	NC		Standby, this pin must be left floating
12	+5V	I	Power input, +5 VDC
13	GND		Logical Ground

3 Working State and Initialization

3.1 Working State

MVB-UDP module has two working states:

- Initialization state: the module enters the initialization state firstly when it starts up, receives or loads the configuration and carries out the system initialization operation;
- Running state: the module enters the running state after initialization, and works according to the configuration.

3.2 Module Initialization Method

MVB-UDP module has two initialization methods:

- Host initialization: after the module is powered on, it obtains configuration data from the host computer through messages and carries out system initialization operation. The system default is Host initialization;
- Local initialization: after the module is powered on, load the configuration data in the on-board FLASH of the module for initialization.

3.3 Host Initialization Programming Interface

Refer to the document *THCP Protocol_Programming Manual*.

4 Building Configuration Environment

4.1 Connect Management Computer to MVB-UDP

MVB-UDP provides a variety of configuration management methods to meet different application scenarios.

After the MVB-UDP is configured, the configuration parameters are saved in FLASH on the MVB-UDP board, and will be automatically loaded to work every time MVB-UDP is powered on or restarted in the future.

4.1.1 Configure with special DMS-UART interface

Connect the special DMS-UART interface (X3) of MVB-UDP to the USB interface of the computer with the DMS-UART-8P configuration cable.



4.1.2 Configuration with Ethernet interface

Users can connect the MVB-UDP to the management computer via Ethernet, and run yacer-DMS configuration management software on the computer to configure and manage the MVB-UDP.

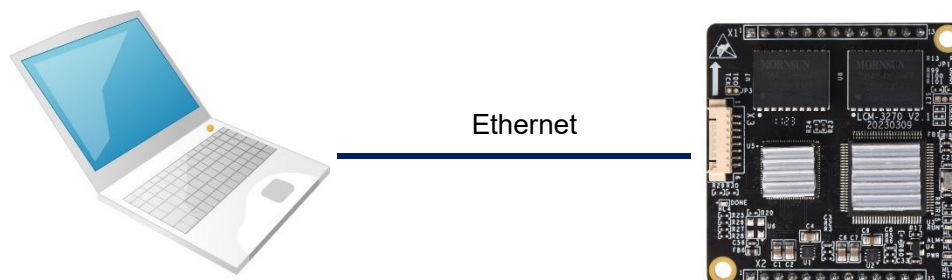

4.2 Get Configuration Management Software yacer-DMS

The user can obtain a compressed package yacer-DMS.zip of configuration management software in the following ways:

- In the “Softwares” directory of the accompanied U disk of MVB-UDP;
- Software channel on the official website (www.yacer.com.cn).

4.3 Run yacer-DMS Software

As the free-installation application software, unzip yacer-DMS.zip, enter the working directory and double click the file yacer-DMS.exe to run.

4.4 Select & Open Configuration Serial Port

When DMS-UART-8P configuration line is connected to the management computer USB interface, the computer will add a USB simulation serial port.

Click the “Interface” button on the toolbar to pop up the “Host Interface for DMS” configuration dialog. Enter the “Serial” page, select the serial port of the computer connected to MVB-UDP from the drop-down list, and click “Open Serial” button.

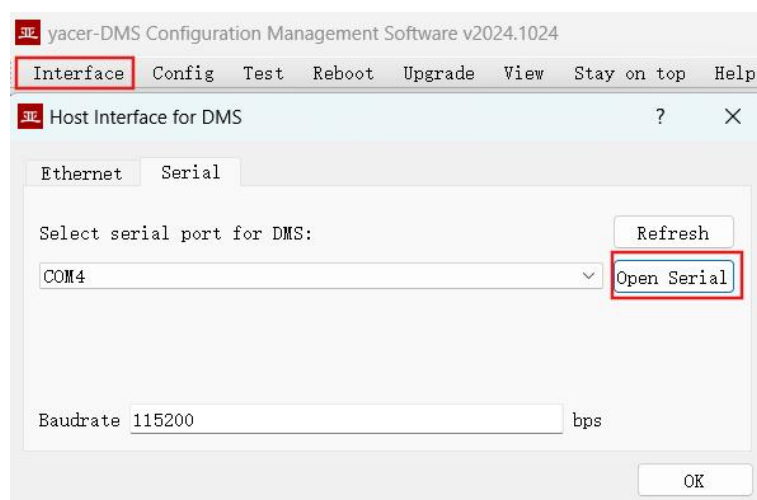

If the serial port is successfully opened, the status is as follows:



4.5 Main Window of yacer-DMS

The following figure is the main interface of the configuration management software, which can be divided into three parts:

- **Toolbar:** Functional operation buttons;
- **Device List:** Displaying the basic information and operation status of online devices;
- **Statistical Report:** Displaying the receive/transmit indication & statistics, and device details.

4.6 Statistical Report

The statistical report has three panels: control panel, receive/transmit indication panel and information panel.

4.6.1 Control panel

Statistical report data is refreshed once per second and can be cleared by clicking the "Clear" button.

4.6.2 Receive & Transmit indication panel

- Tx: The interface sends a frame of data, corresponding Tx indicator blinks once;
- Rx: The interface receives a frame of data, corresponding Rx indicator blinks once.

	Tx	Rx
MVB	<input type="checkbox"/>	<input type="checkbox"/>
SER	<input type="checkbox"/>	<input type="checkbox"/>
UDP	<input type="checkbox"/>	<input type="checkbox"/>

4.6.3 Information panel

The right side of the statistical report is the information panel, which can display the following contents:



- Device information: Running time, S/N and Version number;
- Interface: Receive/transmit statistics of MVB, UART interface and UDP packets on Ethernet interface;
- DMS Service: Configuration management message receive/transmit statistics, MVB device status information.

4.7 Configure Device

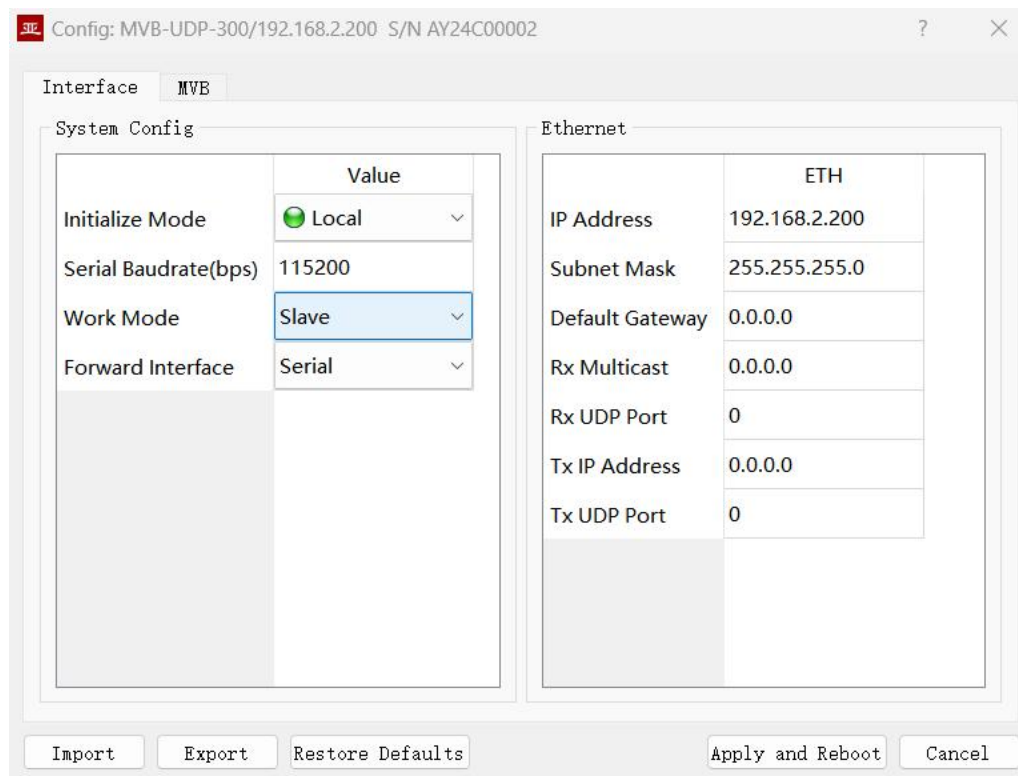
Click the "Device Configuration" button on the toolbar or double-click the selected device in the device list, yacer-DMS pops up the configuration dialog.

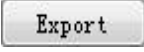

The following action buttons are included at the bottom of the dialog box.

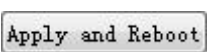
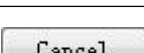
Button	Function
	Open the configuration file, read the configuration parameters refresh the configuration dialog
	Export configuration parameters from the configuration dialog to a file for saving
	Refresh the configuration dialog with the factory parameters
	Write the configuration parameters in the dialog to the device, and restart the device to make the configuration take effect
	Cancel current configuration operation

5 Function and Configuration

5.1 System Configuration

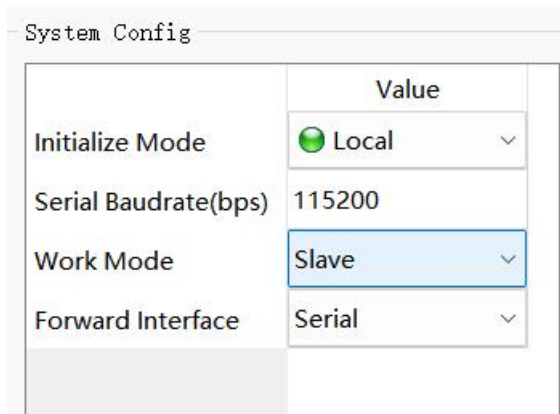

5.1.1 Initialization Method

Configure the initialization method of the module, the factory default is Host method.

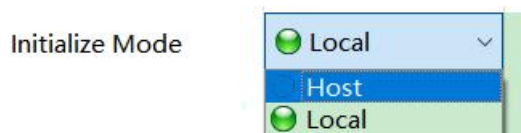

5.1.2 Serial Port Baud Rate

Configure the serial port baud rate.

Other serial port parameters are: data bit 8bit, stop bit 1bit, no parity.

5.1.3 MVB Operating Mode

Module MVB has two modes of operation:

- Slave mode: MVB slave PD bidirectional communication mode;
- Acquisition Mode: Receive all PD data from the MVB bus. The module works in pure reception mode and will not output all frames including device status and PD to the MVB bus.

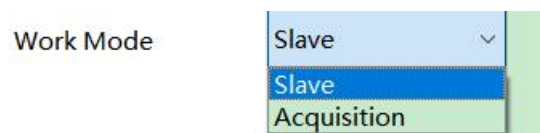

5.1.4 MVB forwarding interface

Local Initialization Mode This configuration is valid.

Host mode indicates the current host interface.

Forward Interface

Serial	▼
Serial	
Ethernet	

5.2 Ethernet Interface Configuration

Ethernet	
	ETH
IP Address	192.168.2.200
Subnet Mask	255.255.255.0
Default Gateway	0.0.0.0
Rx Multicast	224.10.10.10
Rx UDP Port	7000
Tx IP Address	192.168.2.210
Tx UDP Port	6000

This page is used to configure the IP address of Ethernet interface, and the IP and UDP ports for communication between the host computer and MVB-UDP module, including the following:

- IP Address: Configure the IP address of Ethernet interface.
- Subnet Mask: Configure the Subnet Mask of Ethernet interface.
- Default Gateway: Configure the default gateway of Ethernet interface. The default gateway is set to 0 when there is no need to communicate with devices across network segments.
- Receive multicast address: When the host sends messages to MVB-UDP, use this multicast address as the destination IP.
- Receive UDP port: When the host sends messages to MVB-UDP, use this port as the UDP destination port.
- Destination IP address: When MVB-UDP sends messages to the host, use this IP address as the destination IP.
- Destination UDP Port: When MVB-UDP sends messages to the host, use this port as the UDP destination port.

5.3 MVB Configuration

The MVB configuration page is shown below, with the MVB interface and forwarding configuration on the left, and the PD port configuration table on the right.

In Local initialization mode, the module initializes the MVB interface with this configuration.

In Host initialization mode, this page shows the configuration parameters from the host computer.

The screenshot shows the MVB configuration page. On the left, under the 'MVB' tab, there are three configuration fields: 'Device Address' set to 100, 'Media Type' set to EMD, and 'Line Mode' set to Line Both. On the right, there is a table of PD ports with columns for 'PD Port Type', 'PD Port', and 'Port Size'. The table contains 11 rows of data. Below the table are buttons for 'Import', 'Export', 'Restore Defaults', 'Apply and Reboot', and 'Cancel'.

	PD Port Type	PD Port	Port Size
1	Sink Port	1500	32 bytes
2	Source Po	2000	32 bytes
3	Sink Port	3000	8 bytes
4	Disable	3001	8 bytes
5	Sink Port	3002	8 bytes
6	Sink Port	3003	8 bytes
7	Sink Port	3004	8 bytes
8	Sink Port	3005	8 bytes
9	Sink Port	3006	8 bytes
10	Sink Port	3007	8 bytes
11	Sink Port	3008	8 bytes

5.3.1 Device address

Users configure device address in the range of 0 to 4095 according to field requirements.

5.3.2 Media type

According to the application requirements, users can choose the medium type.

The screenshot shows a dropdown menu for 'Media Type'. The menu is open, showing three options: 'ESD', 'ESD', and 'EMD'. The 'EMD' option is currently selected and highlighted in blue.

5.3.3 Line type

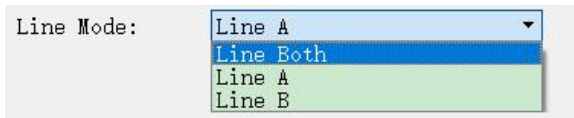

Users can choose:

- Line Both: double-line redundancy;
- Line A: A line single line mode;
- Line B: B line single line mode.

5.3.4 PD port configuration table

The default version of MVB-UDP supports the configuration of up to 32 process data ports. If users need to configure more PD ports, please contact the manufacturer for customization.

Each PD port entry includes the following parameters:

- PD Port Type: Sink or Source port, Disable means this entry is invalid;
- PD Port Number: Set port number 0 ~ 4095;
- PD Port Size: 2, 4, 8, 16, 32 bytes correspond to 0 ~ 4 of Fcode;

5.4 Firmware Version Upgrade

5.4.1 Start upgrade

Click the “Upgrade” button on the toolbar to pop up the version upgrade dialog, and then click the “Start” button.

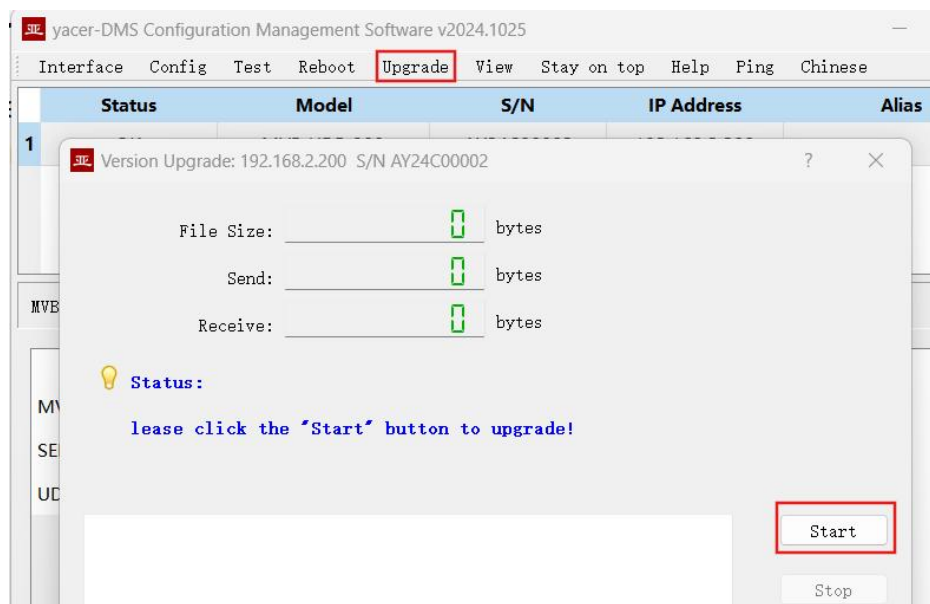

5.4.2 Select version file

Pop up the “Select version file” dialog, and find the folder where the latest firmware version is stored, select the corresponding file, and click “Open” to start the update.

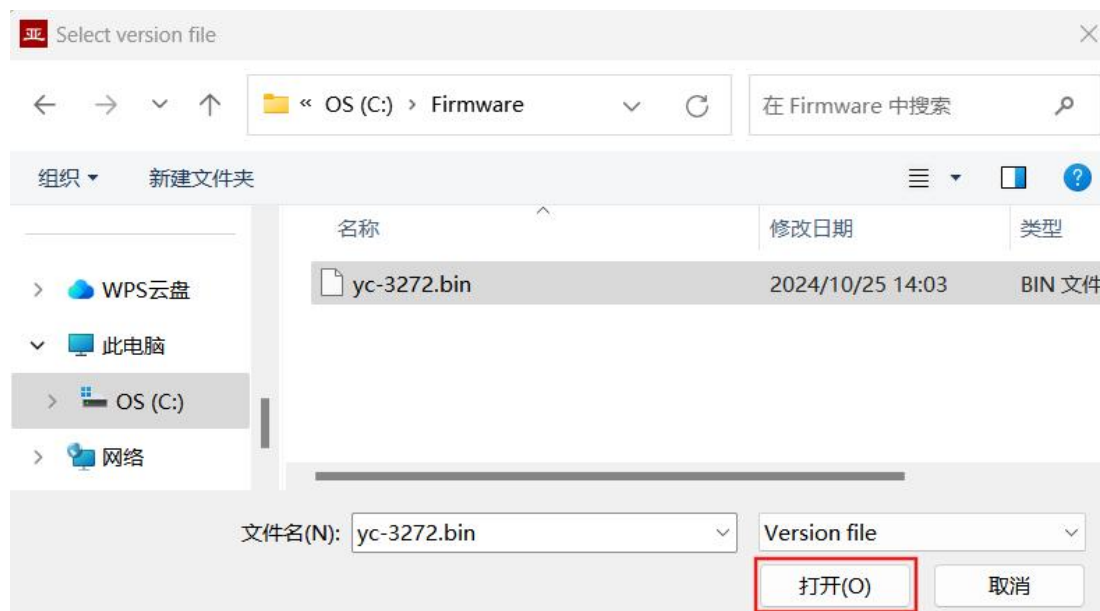

5.4.3 Complete upgrade

When the page displays “Version upgrade complete” status, it indicates that the version upgrade is completed.

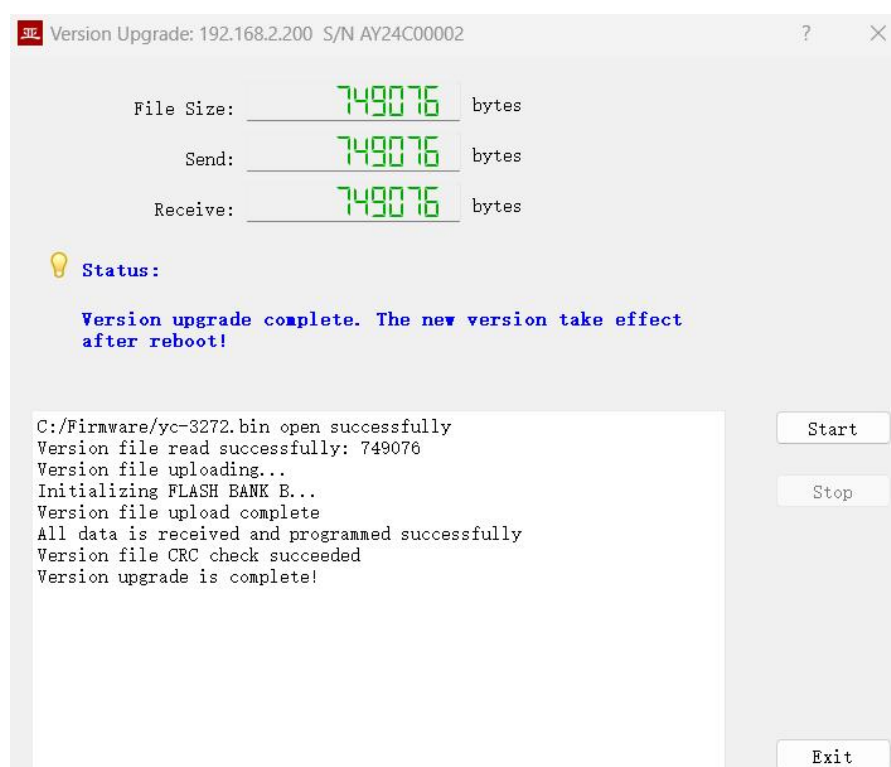

5.4.4 Confirm upgrade

After the upgrade is completed, power up the device again, observe the version information in the statistical report, and determine whether the new version is successfully updated by the version date.



5.5 Reboot Device

Click the “Reboot” button on the toolbar to pop up the device reboot dialog, and then click the “Reboot” button to reboot the device.

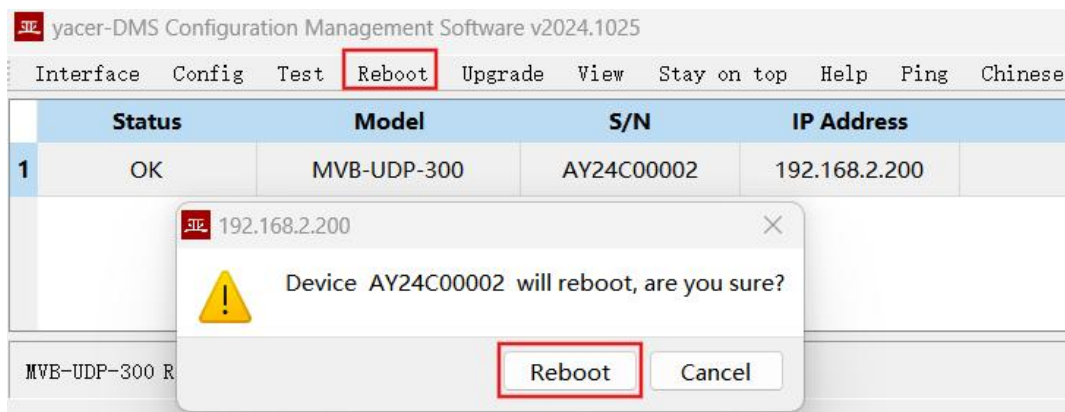

6 Hardware Development

Reference:

- MVB-UDP Hardware Design Guide

7 Software Development

Reference:

- *THCP Protocol Programming Manual*

UART-PPP protocol implementation C code:

- yacer_uart_ppp.c

THCP references C code:

- thcp_inc.h

About the Manual

- The manual is for reference only. If there is inconsistency between the manual and the actual product, the actual product shall prevail.
- We are not liable for any loss caused by the operations that do not comply with the manual.
- All the designs and software are subject to change without prior written notice. The product updates might cause some differences between the actual product and the manual. Please contact the customer service for the latest program and supplementary documentation.
- There still might be deviation in technical data, functions and operations description, or errors in print. If there is any doubt or dispute, we reserve the right of final explanation.
- Upgrade the reader software or try other mainstream reader software if the manual (in PDF format) cannot be opened.
- Please visit our website, contact the supplier or customer service if there is any problem occurring when using the device.
- If there is any uncertainty or controversy, we reserve the right of final explanation.