







# TRDP-MVB

# Datasheet

# Foreword

## Notational Conventions

The following categorized signal words with defined meaning might appear in the manual.

Signal Words	Meaning
 DANGER	Indicates a high potential hazard which, if not avoided, will result in death or serious injury.
 CAUTION	Indicates a potential risk which, if not avoided, could result in property damage, data loss, lower performance, or unpredictable result.
 ANTISTATIC	Indicates static sensitive equipment.
 DANGER! ELECTRIC SHOCK	Indicates High voltage danger.
 TIPS	Provides methods to help you solve a problem or save you time.
 NOTE	Provides additional information as the emphasis and supplement to the text.

# Table of Contents

<b>Foreword</b> .....	<b>I</b>
<b>1 Overview</b> .....	<b>4</b>
1.1 Introduction .....	4
1.2 Applications .....	4
1.3 Features .....	4
1.4 Technical Specifications .....	5
1.5 Mechanical Dimensions .....	6
1.6 Order Information .....	6
<b>2 Hardware and Physical Interfaces</b> .....	<b>7</b>
2.1 Appearance .....	7
2.2 LED Indicators .....	7
2.3 Pin Definition .....	8
2.3.1 X1: 2x15 2.0mm pitch connector .....	8
2.3.2 X2: 2x15 2.0mm pitch connector .....	9
2.4 Ethernet Interface Development .....	10
2.4.1 M12 Connector .....	10
2.4.2 Reference Circuit .....	10
<b>3 Working State and Initialization</b> .....	<b>11</b>
3.1 Working State .....	11
3.2 Module Initialization Mode .....	11
3.3 Host initialization programming interface .....	11
<b>4 System Function</b> .....	<b>12</b>
4.1 TRDP Function Diagram .....	12
4.1.1 TRDP to UART Working Mode .....	12
4.1.2 TRDP to CAN Working Mode .....	12
4.2 MVB Function Diagram .....	13
4.2.1 MVB to UART Working Mode .....	13
4.2.2 MVB to CAN Working Mode .....	14
<b>5 yacer-DMS Configuration Management</b> .....	<b>16</b>
5.1 Get configuration management software yacer-DMS .....	16
5.2 Building Configuration Environment .....	16
5.3 Main Window of yacer-DMS .....	17
5.4 Statistical Report .....	18
5.4.1 Control Panel .....	18
5.4.2 Receive & Transmit Indication Panel .....	18
5.4.3 Information Panel .....	19
5.5 Configure Device .....	19
5.6 System Configuration .....	20
5.6.1 Initialization Mode .....	20
5.6.2 Serial Configuration .....	20
5.6.3 CAN Baudrate .....	20

---

5.6.4 TRDP&MVB Forward Interface .....	20
5.6.5 DMS of Ethernet Interface .....	21
5.7 TRDP Netif .....	21
5.8 TRDP Receive Configuration .....	21
5.9 TRDP Send Configuration .....	22
5.10 MVB Configuration .....	22
5.10.1 Device address .....	23
5.10.2 Media type .....	23
5.10.3 Line type .....	23
5.10.4 PD port configuration table .....	24
5.11 Firmware Version Upgrade .....	24
5.11.1 Start Upgrade .....	24
5.11.2 Select Version File .....	24
5.11.3 Complete Upgrade .....	25
5.11.4 Re-powering takes effect .....	25
5.11.5 Confirm Upgrade .....	26
5.12 Reboot Device .....	26
<b>6 Software Development .....</b>	<b>27</b>

# 1 Overview

## 1.1 Introduction

The Yacer TRDP-MVB embedded communication module provides one redundant MVB interface, two TRDP redundant 100M Ethernet interfaces, one UART serial port, one CAN interface to implement protocol conversion between MVB, TRDP and serial port, CAN interface. Tiny size, 2.0mm pin interface. +3.3V power supply, industrial wide temperature, suitable for embedded custom applications.



## 1.2 Applications

- Protocol conversion between TRDP and CAN interface;
- Protocol conversion between TRDP and serial port;
- Protocol conversion between MVB and CAN interface;
- Protocol conversion between MVB and serial port;
- Train Control and Management System (TCMS);
- Train Communication Network (TCN);
- Embedded application and development.

## 1.3 Features

- Two 100M full-duplex Ethernet interfaces, supports TRDP protocol;
- One MVB redundant interface, supports MVB slave protocol;
- One serial port;
- One CAN bus interface;
- Open and flexible configuration management;
- +3.3V power supply, low power consumption;
- Small size, Industrial wide temperature.

## 1.4 Technical Specifications

Item	Parameters	Details
Ethernet Interface	Number	2 x 100M PHY
	Rate	100 Mbps, supports MDI/MDIX adaptive
	Network protocol	TRDP
Serial Port	Number	1 x 3.3V LVCMOS
	Duplex mode	full-duplex
	Working mode	UART
	Baud rate	≤ 921.6 Kbps
MVB Interface	Number	1 x 3.3V LVCMOS
	Media support	EMD, ESD
	Protocol support	Device_Status, Process_Data(PD)
	Number of PD ports	16
CAN Interface	Level standard	3.3V LVCMOS
	Working mode	CAN 2.0A, CAN 2.0B, ISO 11898
	Baud rate	≤ 1 Mbps
Configuration Management	Configuration tool	yacer-DMS configuration management software
	Configuration interface	Dedicated DMS-UART interface (with the help of yacer DMS-UART-8P configuration cable)
Power Requirements	Power Supply	+3.3 VDC
	Power consumption	< 2W
Mechanical Characteristics	Connector	2x 30 PIN double row pin connectors (2*15) with 2.0mm pitch
	Dimensions	46.5 mm x 48 mm
	Weight	25 g
Operating Environment	Operating temperature	-40 ~ +85°C

Item	Parameters	Details
	Storage temperature	-40 ~ +85°C
	Operating humidity	5 ~ 95% RH (no condensation)

## 1.5 Mechanical Dimensions

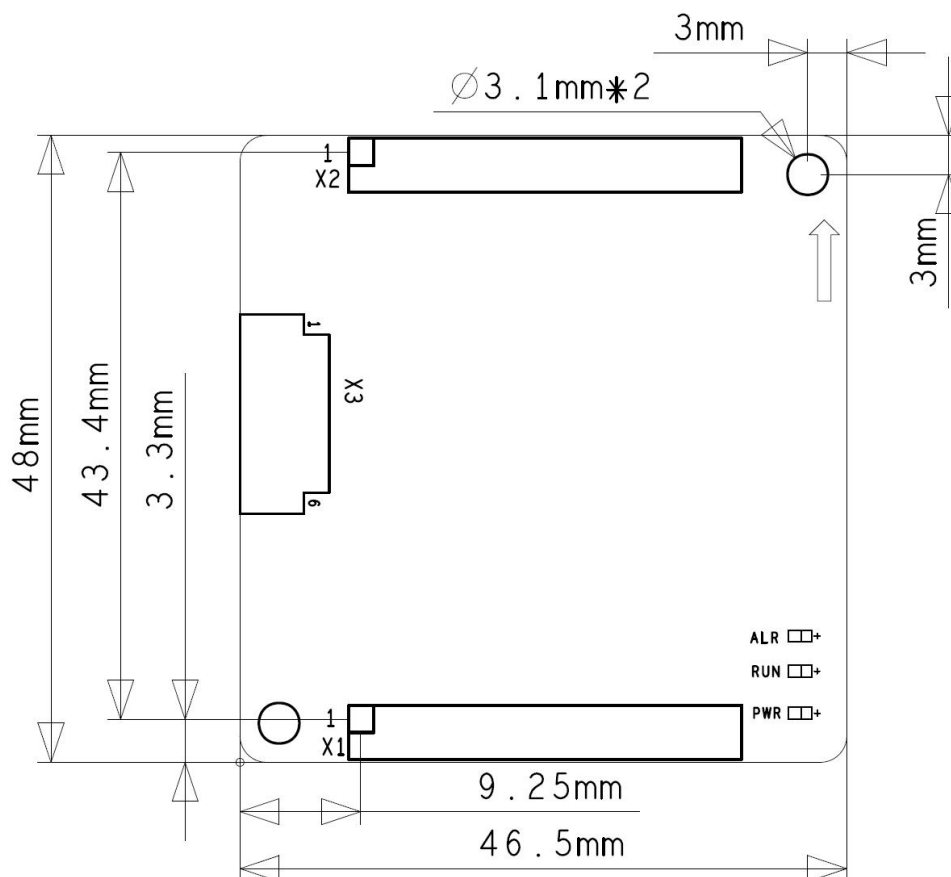

## 1.6 Order Information

Model	MVB Interface	Ethernet Interface	Serial port	CAN Interface
TRDP-MVB-420	1 x MVB	2 x 100M PHY	1 x UART	1 x CAN

## 2 Hardware and Physical Interfaces

### 2.1 Appearance

The top and bottom view of TRDP-MVB are as follows, and the signals are drawn out through connector X1 and X2.

X3 is configuration interface used to connect the DMS-UART-8P configuration cable and configure it online through the management computer's USB interface.

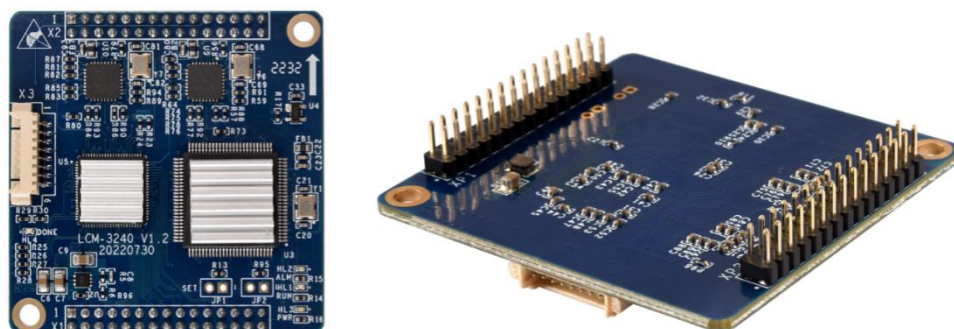

### 2.2 LED Indicators

Item	Description
RUN	Running indicator, green light flashing during normal operation
ALM	Alarm indicator <ul style="list-style-type: none"> <li>● Initialization phase blinking: waiting for the host computer configuration command</li> <li>● Normal operation status off: the device is working normally</li> <li>● Normal operation status on: device failure</li> </ul>
PWR	Power indicator, always on after power on



## 2.3 Pin Definition

### 2.3.1 X1: 2x15 2.0mm pitch connector

Pin	Signal	Type	Description
1	GND		Logic ground
2	GND		Logic ground
3	UART_TXD	O	Serial port data transmission
4	UART_RXD	I	Serial port data reception
5	NC		Standby, this pin must be left floating
6	NC		Standby, this pin must be left floating
7	NC		Standby, this pin must be left floating
8	UART_LED	O	Serial transmit/receive indication, drive LED negative
9	NC		Standby, this pin must be left floating
10	NC		Standby, this pin must be left floating
11	NC		Standby, this pin must be left floating
12	NC		Standby, this pin must be left floating
13	NC		Standby, this pin must be left floating
14	NC		Standby, this pin must be left floating
15	GND		Logic ground
16	GND		Logic ground
17	MVB_A_TXD	O	MVB Line A transmit
18	MVB_A_RXD	I	MVB Line A receive
19	NC		Standby, this pin must be left floating
20	NC		Standby, this pin must be left floating
21	MVB_A_TX_EN	O	MVB Line A transmitter enable control, enable level is high
22	NC		Standby, this pin must be left floating
23	MVB_B_TXD	O	MVB Line B transmit
24	MVB_B_RXD	I	MVB Line B receive
25	NC		Standby, this pin must be left floating
26	NC		Standby, this pin must be left floating
27	MVB_B_TX_EN	O	MVB Line B transmitter enable control, enable level is high
28	NC		Standby, this pin must be left floating
29	GND		Logic ground
30	GND		Logic ground

## 2.3.2 X2: 2x15 2.0mm pitch connector

Pin	Signal	Type	Description
1	GND		Logic ground
2	GND		Logic ground
3	VCC3V3	I	Power input, +3.3 VDC
4	VCC3V3	I	Power input, +3.3 VDC
5	NC		Standby, this pin must be left floating
6	NC		Standby, this pin must be left floating
7	RESET_IN	I	Module reset input, active low. Power-On Reset supported, Pin can be suspended.
8	NC		Standby, this pin must be left floating
9	NC		Standby, this pin must be left floating
10	NC		Standby, this pin must be left floating
11	LED_RUN	O	System operation indication, active low
12	LED_ALARM	O	System alarm indication, active low
13	CAN_TX	O	CAN interface data transmission
14	CAN_RX	I	CAN interface data reception
15	GND		Logic ground
16	GND		Logic ground
17	ETH1_TX+		Tx+ for Ethernet PHY interface 1, external network transformer required
18	ETH1_TX-		Tx- for Ethernet PHY interface 1, external network transformer required
19	ETH1_RX+		Rx+ for Ethernet PHY interface 1, external network transformer required
20	ETH1_RX-		Rx- for Ethernet PHY interface 1, external network transformer required
21	LED_ETH1		Link/Act indication for Ethernet 1, drives positive LED
22	NC		Standby, this pin must be left floating
23	ETH2_TX+		Tx+ for Ethernet PHY interface 2, external network transformer required
24	ETH2_TX-		Tx- for Ethernet PHY interface 2, external network transformer required
25	ETH2_RX+		Rx+ for Ethernet PHY interface 2, external network transformer required
26	ETH2_RX-		Rx- for Ethernet PHY interface 2, external network transformer required
27	LED_ETH2		Link/Act indication for Ethernet 2, drives positive LED
28	NC		Standby, this pin must be left floating
29	GND		Logic ground
30	GND		Logic ground

## 2.4 Ethernet Interface Development

### 2.4.1 M12 Connector

The train Ethernet interface uses the M12 connector (D-type coded hole) of IEC 61706-2-101 standard. The socket front view and pins are defined as follows:

Pin	Description
1	TD +
2	RD +
3	TD -
4	RD -

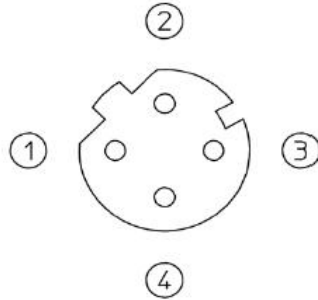

### 2.4.2 Reference Circuit

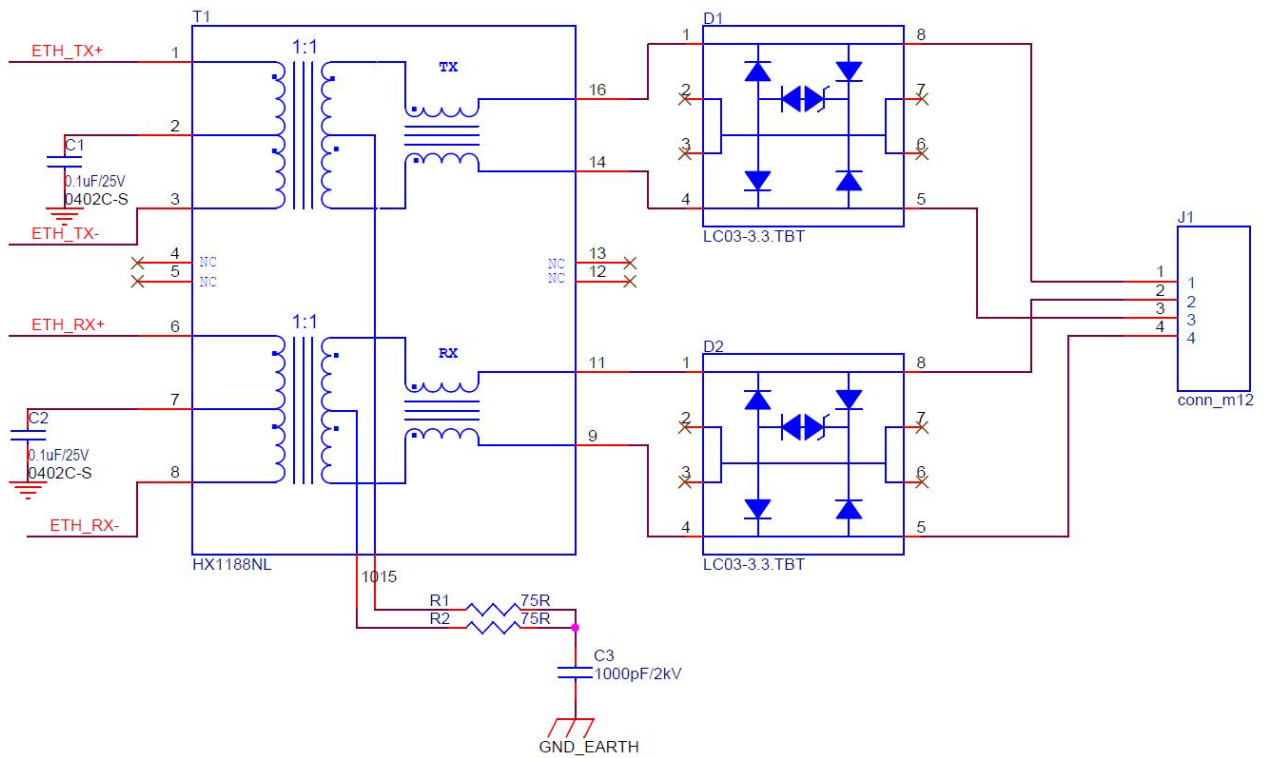

## 3 Working State and Initialization

### 3.1 Working State

The TRDP-MVB module has two working states:

- Initialization state: When the module is powered up, it enters the initialization state first, receives or loads the configuration, and performs the system initialization operation.
- Running state: After the module is initialized, it enters the running state and works according to the configuration.

### 3.2 Module Initialization Mode

The TRDP-MVB module has two initialization methods:

- Host initialization: After the module is powered on, it obtains configuration data from the host through messages and initializes the system. The default initialization mode is Host.
- Local initialization: After the module is powered on, it loads the configuration data from the module's onboard FLASH for initialization.

### 3.3 Host initialization programming interface

Reference document "THCP Protocol Programming Manual".

## 4 System Function

### 4.1 TRDP Function Diagram

#### 4.1.1 TRDP to UART Working Mode

The two Ethernet ports of TRDP-MVB can be configured to support the TRDP protocol. TRDP-MVB interacts data with the host computer through UART. The process is as follows

- TRDP Send: The host computer sends data to the UART interface of TRDP-MVB through the serial port. TRDP-MVB converts the data to TRDP PD data and sends it out through Ethernet;
- TRDP Receive: TRDP-MVB receives the subscribed TRDP PD data from the Ethernet port and forward it to the host computer via the UART interface.

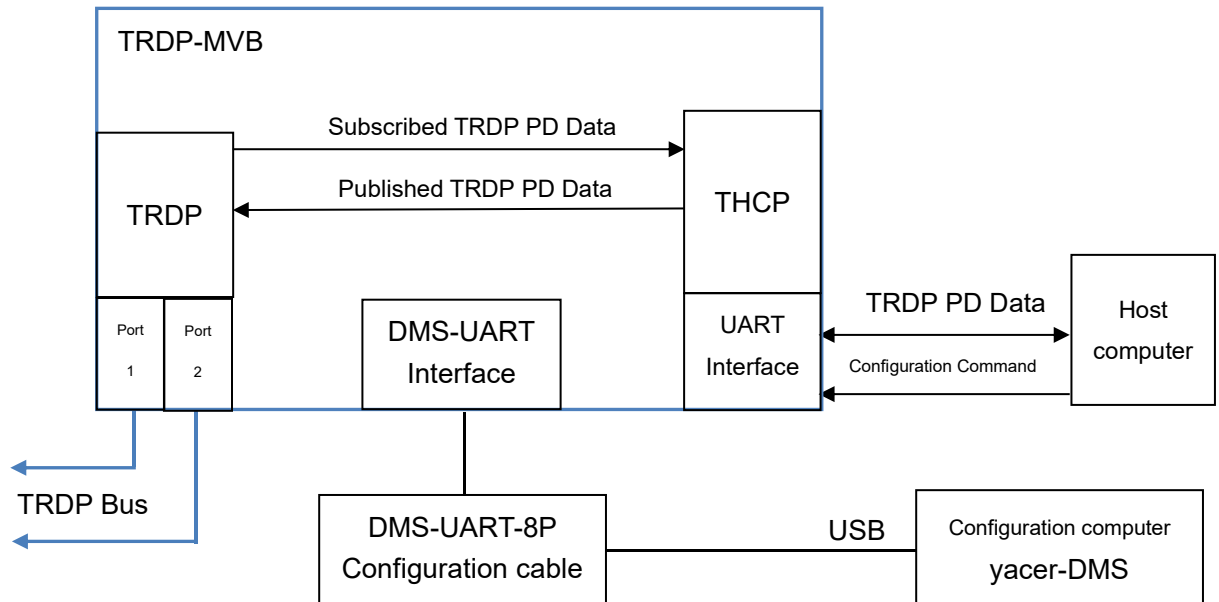

For reliable data transmission with the host computer through the UART interface, the TRDP-MVB uses the UART-PPP protocol to encapsulate the data which is detailed in “THCP\_Programming\_Manual”.

For the UART-PPP library and data command format required for the software development of the host computer, please contact the manufacturer's technical support.

#### 4.1.2 TRDP to CAN Working Mode

The two Ethernet ports of TRDP-MVB can be configured to support the TRDP protocol. TRDP-MVB interacts data with the host computer through CAN interface. The process is as follows:

- TRDP Send: The host computer sends data to the CAN interface of TRDP-MVB. TRDP-MVB converts the data to TRDP PD data and sends it out through Ethernet;

- TRDP Receive: TRDP-MVB receives the subscribed TRDP PD data from the Ethernet port and forward it to the host computer via the CAN interface.

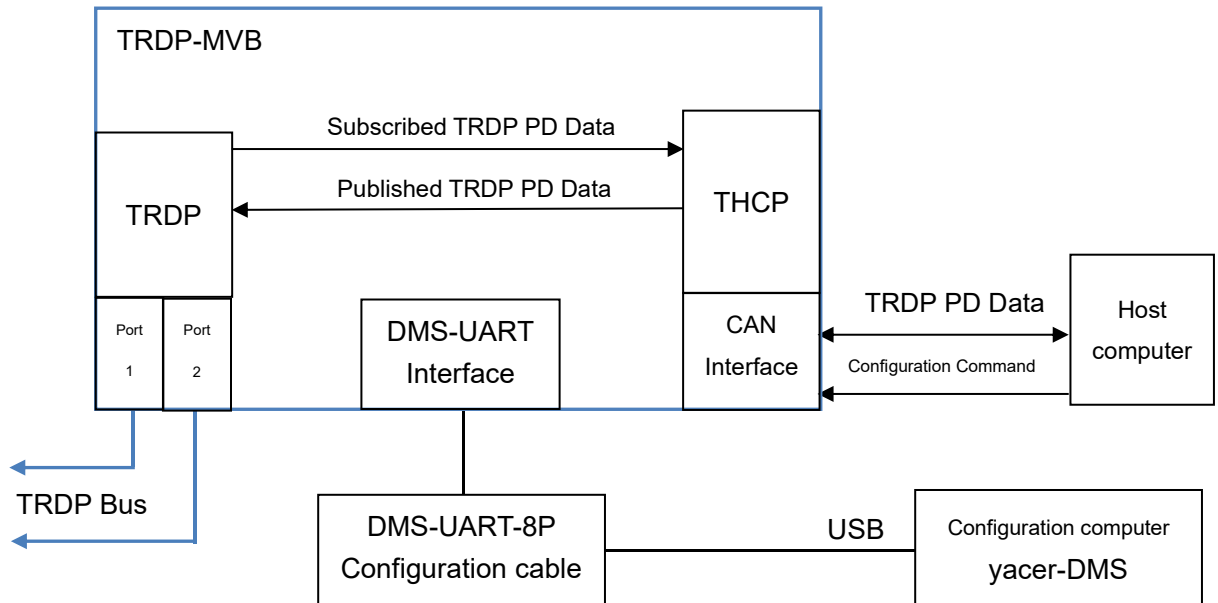

For reliable data transmission with the host computer through the CAN interface, the TRDP-MVB uses the extended CAN frame based on CAN2.0B to encapsulate the data which is detailed in “THCP\_Programming\_Manual”.

For the THCP CAN translation codes and data command format required for the software development of the host computer, please contact the manufacturer's technical support.

## 4.2 MVB Function Diagram

### 4.2.1 MVB to UART Working Mode

One redundant MVB interface of TRDP-MVB can be configured to support the MVB protocol. TRDP-MVB interacts data with the host computer through UART. The process is as follows

- MVB Send: The host computer sends source port PD data to the UART interface of TRDP-MVB through the serial port. TRDP-MVB converts PD data and sends slave frame with the data when MVB master polls;
- MVB Receive: TRDP-MVB receives the sink port PD data from the MVB interface and forward it to the host computer via the UART interface.

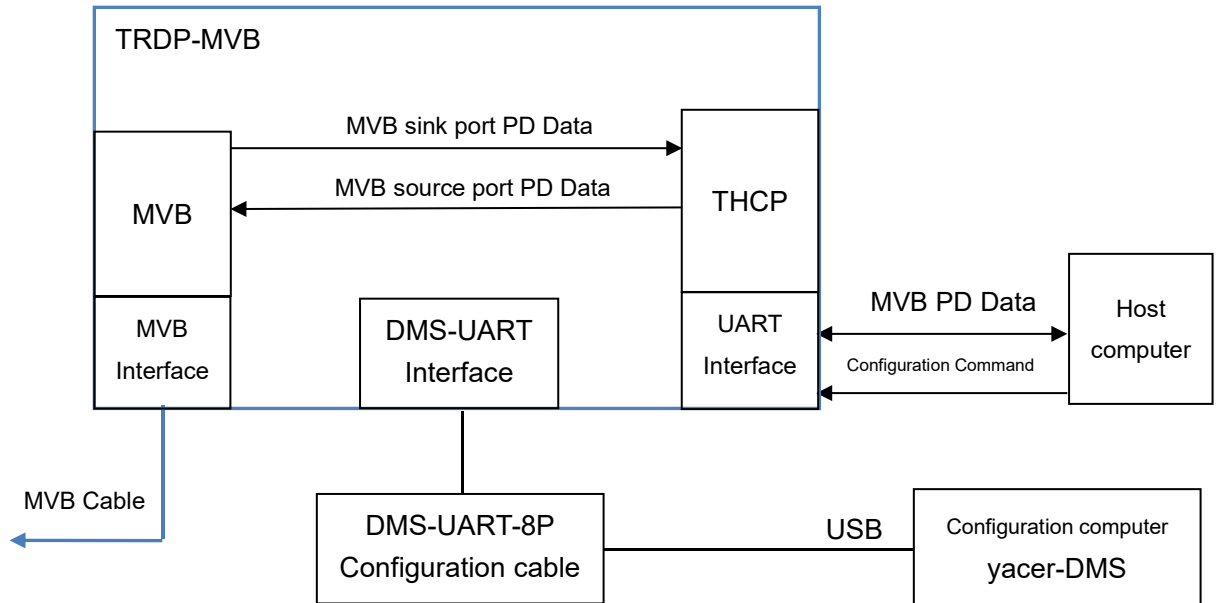

For reliable data transmission with the host computer through the UART interface, the TRDP-MVB uses the UART-PPP protocol to encapsulate the data which is detailed in “THCP\_Programming\_Manual”.

For the UART-PPP library and data command format required for the software development of the host computer, please contact the manufacturer’s technical support.

## 4.2.2 MVB to CAN Working Mode

One redundant MVB interface of TRDP-MVB can be configured to support the MVB protocol. TRDP-MVB interacts data with the host computer through CAN interface. The process is as follows

- MVB Send: The host computer sends source port PD data to the CAN interface of TRDP-MVB. TRDP-MVB converts PD data and sends slave frame with the data when MVB master polls;
- MVB Receive: TRDP-MVB receives the sink port PD data from the MVB interface and forward it to the host computer via the CAN interface.

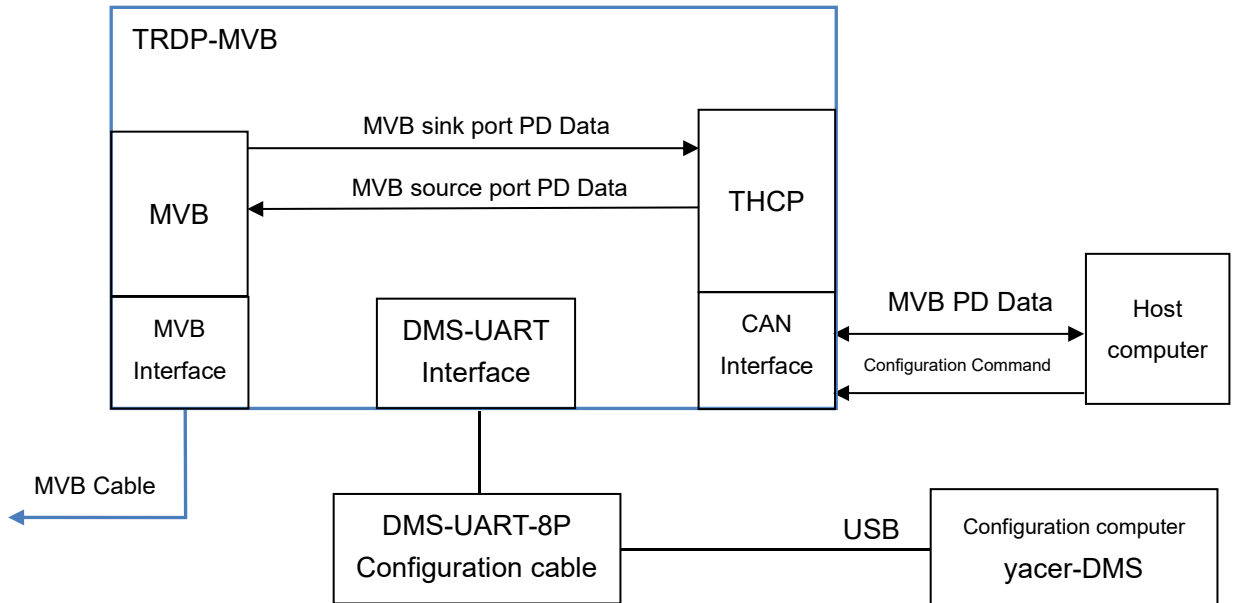

For reliable data transmission with the host computer through the CAN interface, the TRDP-MVB uses the extended CAN frame based on CAN2.0B to encapsulate the data which is detailed in “THCP\_Programming\_Manual”.

For the THCP CAN translation codes and data command format required for the software development of the host computer, please contact the manufacturer's technical support.



## 5 yacer-DMS Configuration Management

### 5.1 Get configuration management software yacer-DMS

The user can obtain a compressed package yacer-DMS.zip of configuration management software in the following ways:

- In the “Softwares” directory of the accompanied U disk of TRDP-MVB;
- Software channel on the official website ([www.yacer.com.cn](http://www.yacer.com.cn)).

The yacer-DMS is a free-installation application software, unzip yacer-DMS.zip, enter the working directory and double click the file yacer-DMS.exe to run.

### 5.2 Building Configuration Environment

User can configure TRDP-MVB via DMS-UART (X3) interface.

- The DMS-UART-8P configuration cable is used to connect the TRDP-MVB's DMS-UART interface (X3) to the computer's USB port.

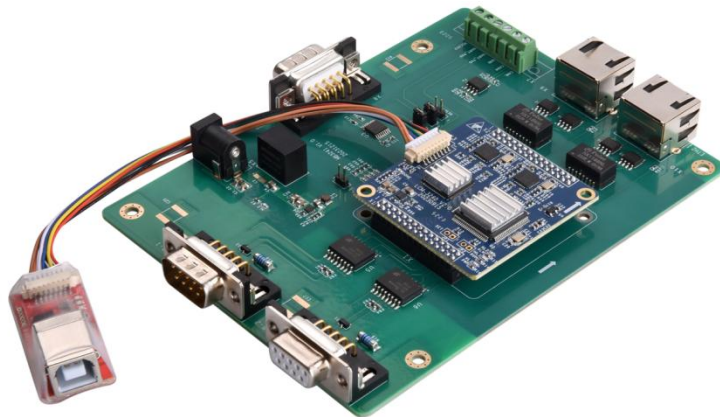

- When DMS-UART-8P configuration cable is connected to the management computer USB interface, the computer will add a USB simulation serial port.
- Click the “Interface” button on the toolbar to pop up the “Host Interface for DMS” configuration dialog. Enter the “Serial” page, select the serial port of the computer connected to TRDP-MVB from the drop-down list, and click “Open Serial” button.

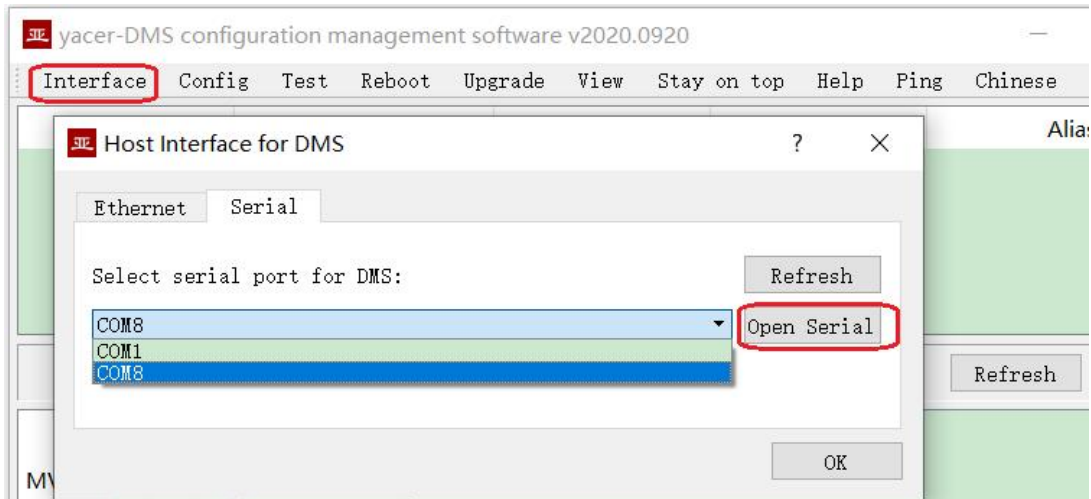

If the serial port is successfully opened, the status is as follows:

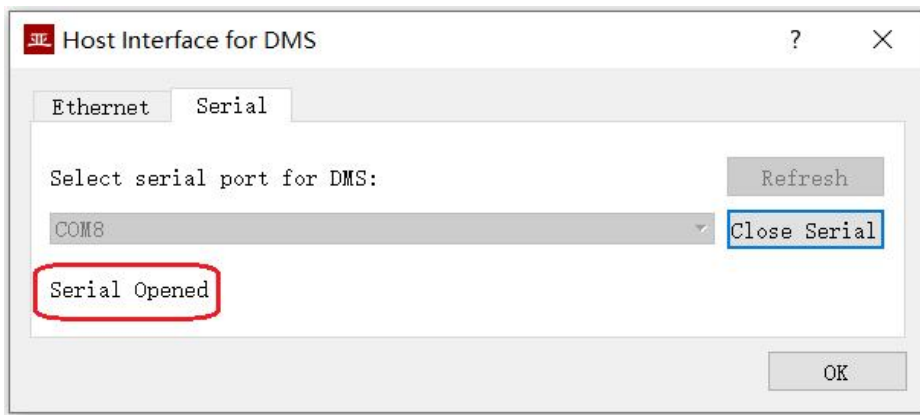

## 5.3 Main Window of yacer-DMS

The following figure is the main interface of the configuration management software, which can be divided into three parts:

- Toolbar: Functional operation buttons;
- Device List: Display the basic information and operation status of online devices;
- Statistical Report: Display the receive/transmit indications, device details, and data transmit/receive statistics.

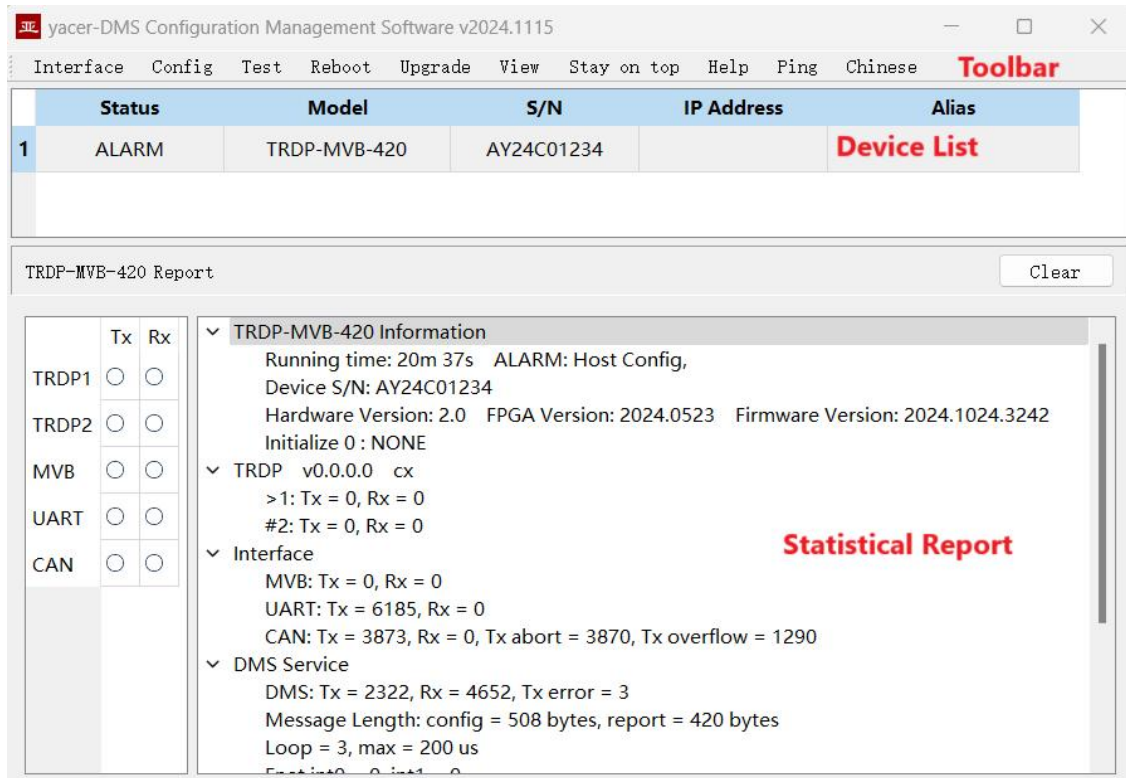

## 5.4 Statistical Report

The statistical report has three panels: control panel, receive/transmit indication panel and information panel.

### 5.4.1 Control Panel

Statistical reports are refreshed once per second, and the statistics can be cleared by clicking the "Clear" button.

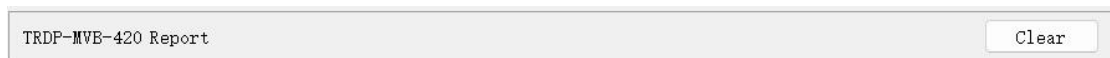

### 5.4.2 Receive & Transmit Indication Panel

- Tx: The interface sends a frame of data, corresponding Tx indicator blinks once;
- Rx: The interface receives a frame of data, corresponding Rx indicator blinks once.

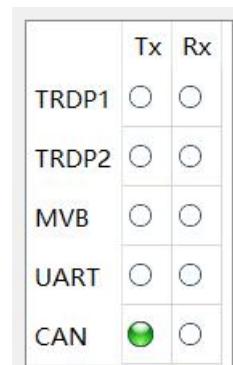

### 5.4.3 Information Panel

Display the following content:

- Device information: Running time, S/N, IP address and Version number;
- TRDP: TRDP protocol receive/transmit statistics;
- Interface: Receive/transmit statistics of MVB, UART and CAN interface;
- DMS Service: Displays receive/transmit statistics on configuration management messages between the device and the management computer

## 5.5 Configure Device

Click the 'Config' button on the toolbar or double-click the selected device in the device list, yacer-DMS pops up the configuration dialog. According to the interface and function, the dialog divides the configuration items into several configuration pages.

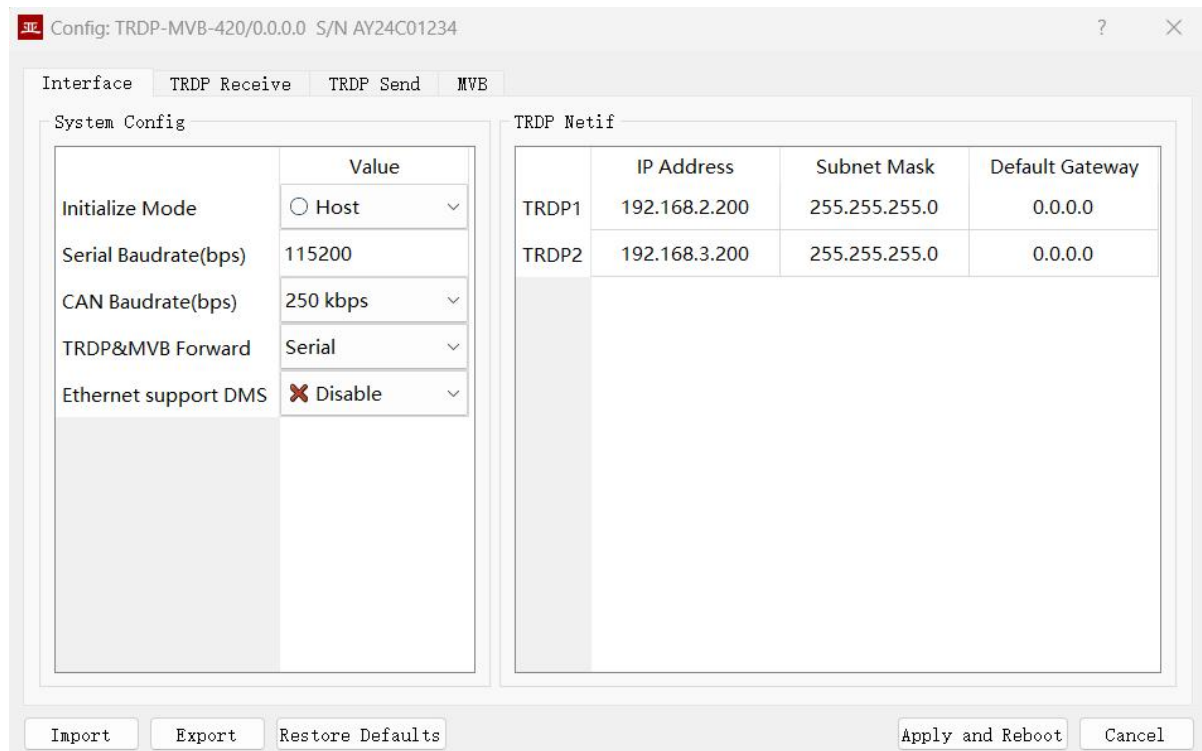

The bottom of the dialog box includes the following operation buttons:

Button	Function
Import	Open the configuration file, read the configuration parameters refresh the configuration dialog
Export	Export configuration parameters from the configuration dialog to a file for saving
Restore Defaults	Refresh the configuration dialog with the factory paramters
Apply and Reboot	Write the configuration parameters in the dialog to the device, and restart the device to make the configuration take effect

Button	Function
	Cancel current configuration operation

## 5.6 System Configuration

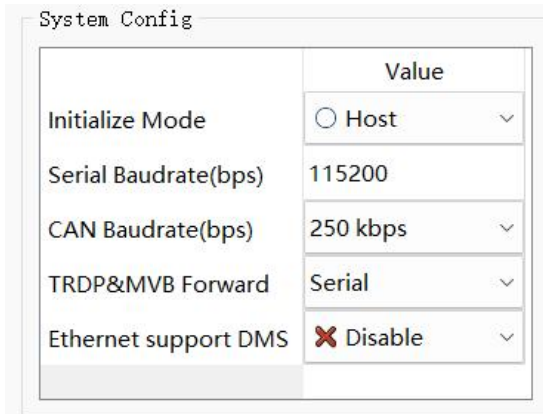

The System Config dialog box contains the following settings:

Parameter	Value
Initialize Mode	<input type="radio"/> Host
Serial Baudrate(bps)	115200
CAN Baudrate(bps)	250 kbps
TRDP&MVB Forward	Serial
Ethernet support DMS	<input checked="" type="checkbox"/> Disable

### 5.6.1 Initialization Mode

Configure the initialization mode for TRDP-MVB module, and the factory default value is Host.

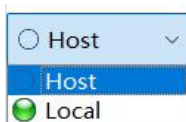

The dropdown menu shows the following options:

- Host
- Host
- Local

### 5.6.2 Serial Configuration

Configure the baud rate for serial port. Other serial port parameters are: 8-bit data bit, 1-bit stop bit, and no parity.

Serial Baudrate(bps)

### 5.6.3 CAN Baudrate

Configure the baud rate for CAN interface.

CAN Baudrate(bps)

### 5.6.4 TRDP&MVB Forward Interface

In Local initialization mode, this configuration is valid.

In Host mode, it indicates the current working interface between host and TRDP-MVB module, and can't be changed by configuration.

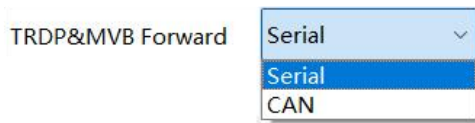

## 5.6.5 DMS of Ethernet Interface

Configure Ethernet interfaces to support DMS function, and Ethernet interfaces doesn't enable DMS function by default.



## 5.7 TRDP Netif

TRDP1 and TRDP2 are redundant TRDP network ports, which are forced to work in 100M full-duplex mode.

TRDP Netif			
	IP Address	Subnet Mask	Default Gateway
TRDP1	192.168.2.200	255.255.255.0	0.0.0.0
TRDP2	192.168.3.200	255.255.255.0	0.0.0.0

## 5.8 TRDP Receive Configuration

This page can configure up to 16 TRDP PD Subscribe entries and supports multicast reception. The subscribed TRDP PD data is forwarded to the host computer through the UART or CAN interface.

In Local initialization mode, TRDP-MVB module initializes the TRDP PD Subscribe entries with this configuration.

In Host initialization mode, this page shows the configuration parameters from the host.

Interface				
TRDP Receive		TRDP Send		MVB
TRDP PD Subscribe				
	TRDP Netif	TRDP Rx COMID	TRDP Rx Multicast	
1	TRDP1	3	224.1.1.5	
2	TRDP2	4	224.1.1.6	
3	Disable	0	0.0.0.0	
4	Disable	0	0.0.0.0	
5	Disable	0	0.0.0.0	
6	Disable	0	0.0.0.0	
7	Disable	0	0.0.0.0	
8	Disable	0	0.0.0.0	

## 5.9 TRDP Send Configuration

This page can configure up to 16 TRDP PD Publish entries.

TRDP-MVB receives data from the host computer through UART or CAN interface, refreshes the PD buffer of TRDP protocol, and then periodically sends PD data according to the configuration. Its destination address can be unicast, multicast, or broadcast.

In Local initialization mode, TRDP-MVB module initializes the TRDP PD Publish entries with this configuration.

In Host initialization mode, this page shows the configuration parameters from the host.

Interface				
TRDP Receive		TRDP Send		MVB
TRDP PD Publish				
	TRDP Netif	TRDP Tx COMID	TRDP Tx Interval(ms)	TRDP Tx Destination IP
1	TRDP1	5	500	224.1.2.1
2	TRDP2	6	500	224.2.2.1
3	Disable	0	0	0.0.0.0
4	Disable	0	0	0.0.0.0
5	Disable	0	0	0.0.0.0
6	Disable	0	0	0.0.0.0
7	Disable	0	0	0.0.0.0
8	Disable	0	0	0.0.0.0

## 5.10 MVB Configuration

The MVB configuration page is shown below, with the MVB interface configuration on the left, and the PD port configuration table on the right.

In Local initialization mode, TRDP-MVB module initializes the MVB interface with this configuration.

In Host initialization mode, this page shows the configuration parameters from the host.

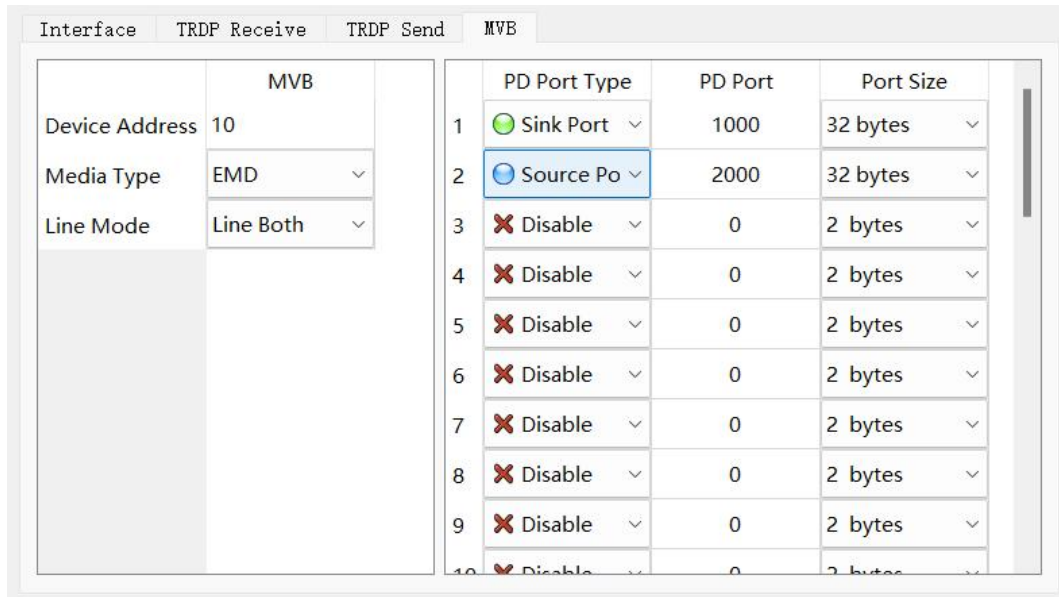

### 5.10.1 Device address

Users configure device address in the range of 0 to 4095 according to field requirements.

### 5.10.2 Media type

According to the application requirements, users can choose the medium type.

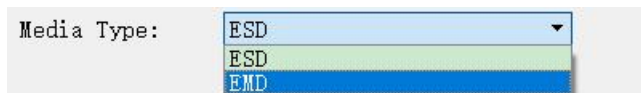

### 5.10.3 Line type

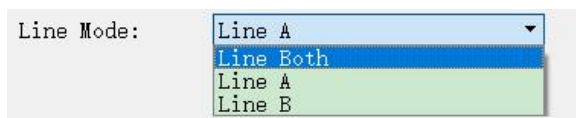

Users can choose:

- Line Both: double-line redundancy;
- Line A: A line single line mode;
- Line B: B line single line mode.



## 5.10.4 PD port configuration table

The default version of TRDP-MVB supports the configuration of up to 16 process data ports. If users need to configure more PD ports, please contact the manufacturer for customization.

Each PD port entry includes the following parameters:

- PD Port Type: Sink or Source port, Disable means this entry is invalid;
- PD Port Number: Set port number 0 ~ 4095;
- PD Port Size: 2, 4, 8, 16, 32 bytes correspond to 0 ~ 4 of Fcode;

## 5.11 Firmware Version Upgrade

### 5.11.1 Start Upgrade

Click the “Upgrade” button on the toolbar to pop up the version upgrade dialog, and then click the “Start” button.

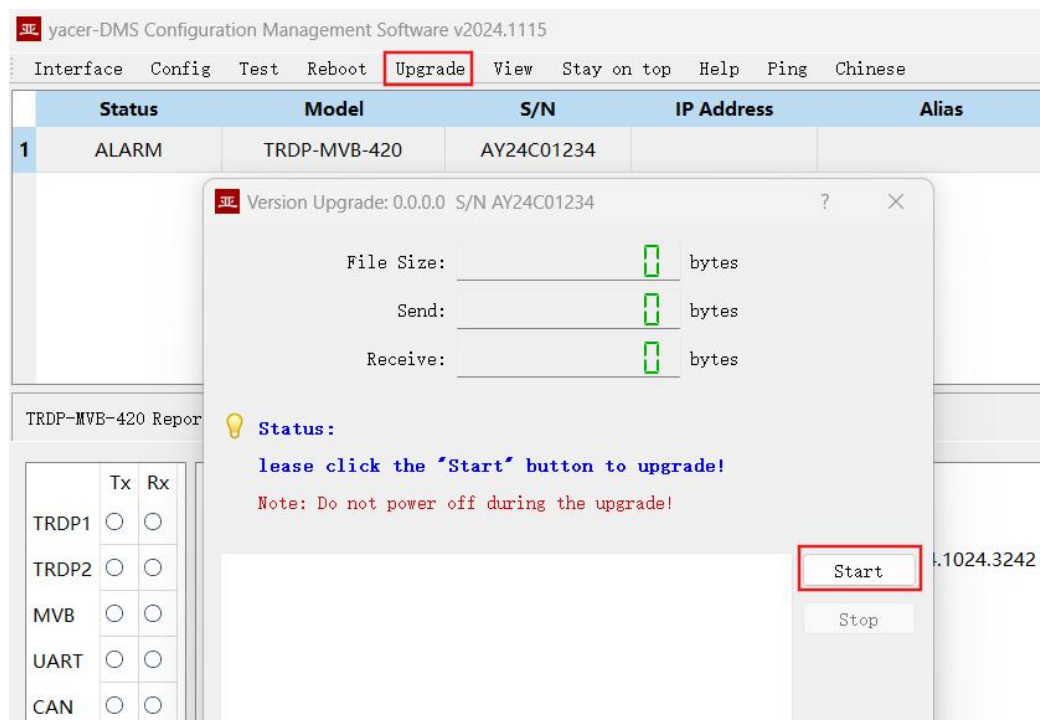

### 5.11.2 Select Version File

Pop up the “Select version file” dialog, and find the folder where the latest firmware version is stored, select the corresponding file, and click “Open” to start the update.

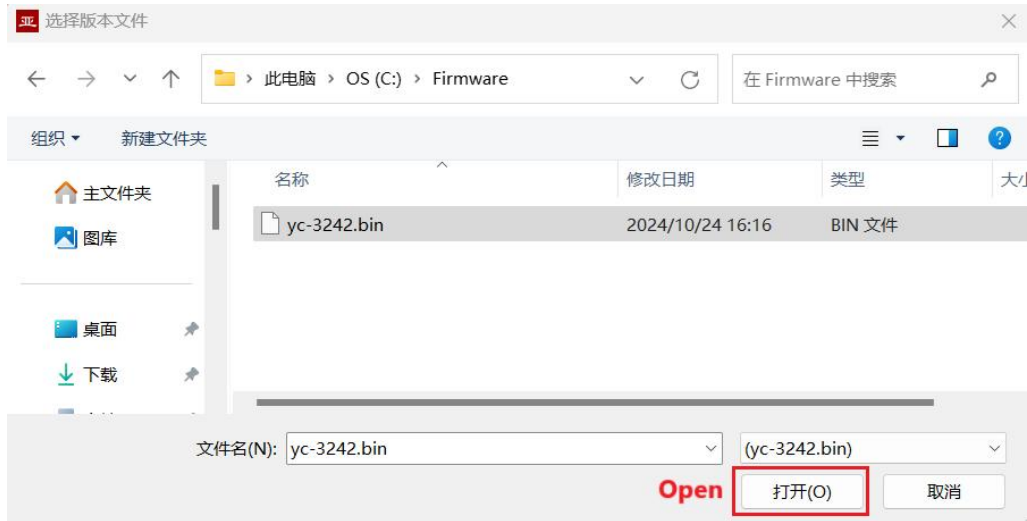

### 5.11.3 Complete Upgrade

After the update is completed, the status of the page will show "Version Update Complete", which means the update is complete. Click the "Exit" button to close the update window.

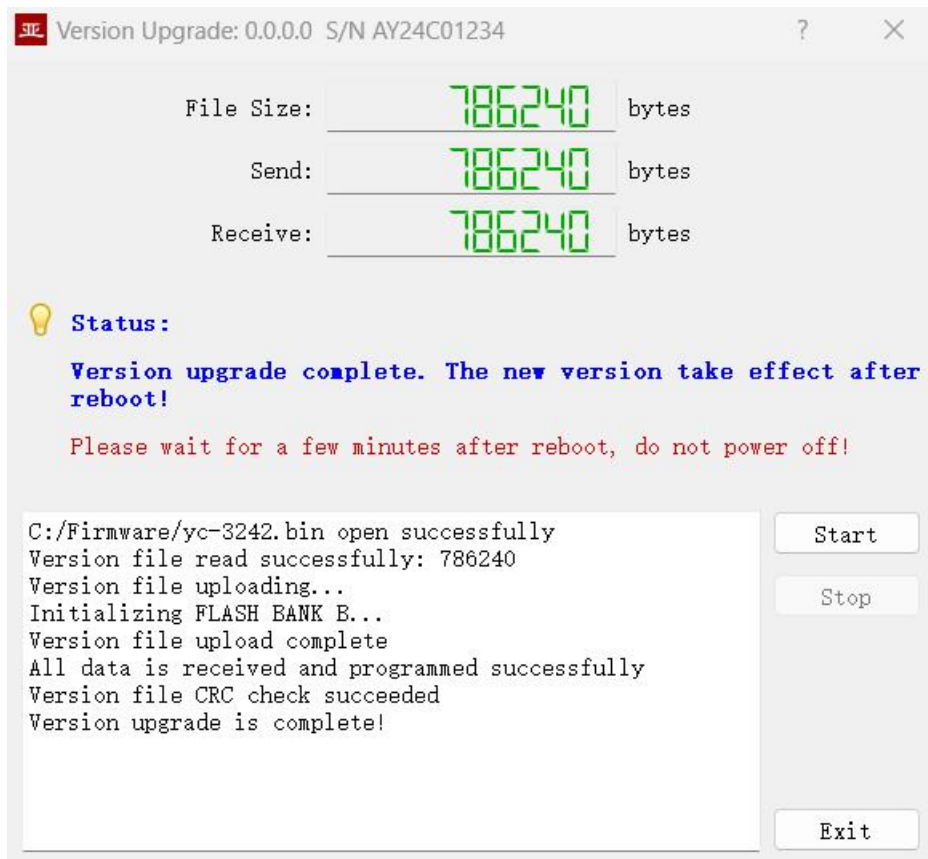

### 5.11.4 Re-powering takes effect

The device is re-powered. Wait for a minute or so for the new version to start taking effect.

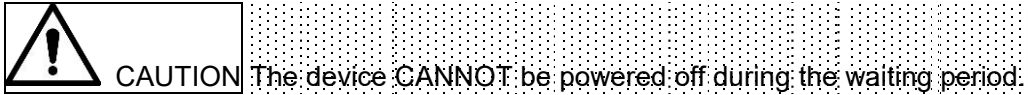

### 5.11.5 Confirm Upgrade

Observe the version information in the statistics report after the device has finished booting and determine whether the update was successful by the version date.



### 5.12 Reboot Device

Click the “Reboot” button on the toolbar to pop up the device reboot dialog, and then click the “Reboot” button to reboot the device.

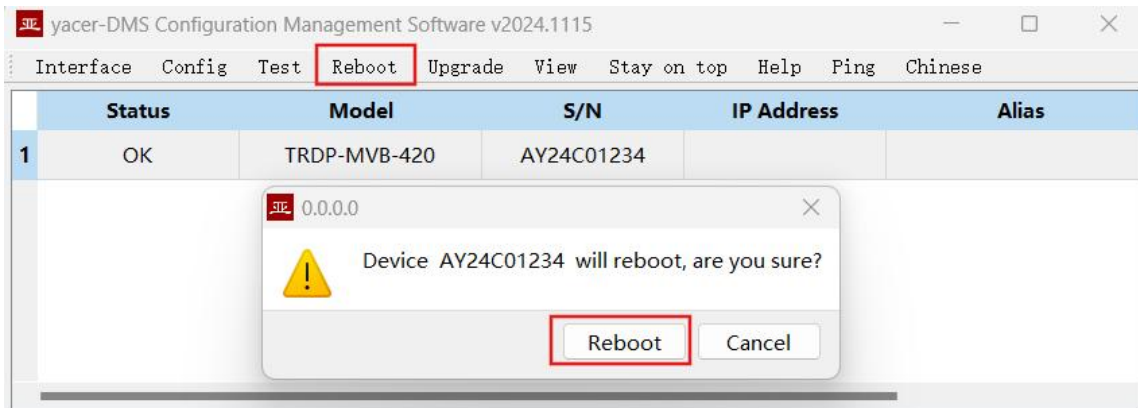

## 6 Software Development

Reference:

- *THCP Protocol Programming Manual*

UART-PPP protocol implementation C code:

- `yacer_uart_ppp.c`

THCP references C code:

- `thcp_inc.h`
- `thcp_canInc.h`
- `thcp_can.c`: The THCP protocol CAN translates code

## About the Manual

- The manual is for reference only. If there is inconsistency between the manual and the actual product, the actual product shall prevail.
- We are not liable for any loss caused by the operations that do not comply with the manual.
- All the designs and software are subject to change without prior written notice. The product updates might cause some differences between the actual product and the manual. Please contact the customer service for the latest program and supplementary documentation.
- There still might be deviation in technical data, functions and operations description, or errors in print. If there is any doubt or dispute, we reserve the right of final explanation.
- Upgrade the reader software or try other mainstream reader software if the manual (in PDF format) cannot be opened.
- Please visit our website, contact the supplier or customer service if there is any problem occurring when using the device.
- If there is any uncertainty or controversy, we reserve the right of final explanation.