

HDLC-ATC

Datasheet

Email: yacer@yacer.cn

Web: www.yacer.com.cn

Foreword

Notational Conventions

The following categorized signal words with defined meaning might appear in the manual.







Signal Words	Meaning
 DANGER	Indicates a high potential hazard which, if not avoided, will result in death or serious injury.
 CAUTION	Indicates a potential risk which, if not avoided, could result in property damage, data loss, lower performance, or unpredictable result.
 ANTISTATIC	Indicates static sensitive equipment.
 DANGER! ELECTRIC SHOCK	Indicates High voltage danger.
 TIPS	Provides methods to help you solve a problem or save you time.
 NOTE	Provides additional information as the emphasis and supplement to the text.

Table of Contents

Foreword	I
1 Overview	4
1.1 Introduction	4
1.2 Features	4
1.3 Application	4
1.4 Technical Specifications	5
1.5 Order Information	5
2 Hardware and Physical Interface	6
2.1 Chassis and panels	6
2.2 LED Indicators	6
2.3 Ethernet Interfaces	6
2.4 Serial Interface	7
3 Building Configuration Environment	8
3.1 Connect the configuration computer with HDLC-ATC	8
3.2 Get configuration management software yacer-DMS	8
3.3 Run yacer-DMS software	8
3.4 Main Window of yacer-DMS	9
3.5 Statistical Report	9
3.5.1 Control Panel	9
3.5.2 Receive/Transmit Indication Panel	10
3.5.3 Information Panel	10
3.6 Configure Device	11
4 Function and Configuration	12
4.1 Ethernet Interface	12
4.1.1 Device alias	12
4.1.2 IP configuration	12
4.1.3 Default Gateway	13
4.1.4 Announce Configuration	14
4.2 Serial Port	15
4.2.1 Working mode of the serial port	15
4.2.2 HDLC-NRZ Parameter Configuration	16
4.2.3 UART Options	19
4.2.4 UART-PPP Options	20
4.3 UDP to Serial	21
4.3.1 Function Description	21
4.3.2 Protocol Conversion	21
4.3.3 Forwarding Configuration	22
4.3.4 Receive Multicast	22
4.4 Serial to UDP	23
4.4.1 Function Description	23
4.4.2 Protocol Conversion	23

4.4.3 Forwarding Configuration	24
4.4.4 How UDP Server identifies Source Serial ports	24
4.5 Serial to Serial	26
5 System Maintenance	27
5.1 Firmware Version Upgrade	27
5.1.1 Start Upgrade	27
5.1.2 Select Version File	27
5.1.3 Complete Upgrade	28
5.1.4 Confirm Upgrade	28
5.2 Reboot Device	29
6 Application of Protocol Conversion	30
6.1 Application Packet and Conversion Model	30
6.2 UDP Message Format	31
6.3 HDLC Frame Format	31
6.4 UART Data Packet	31
6.5 UART-PPP Frame Format	32

1 Overview

1.1 Introduction

The Yacer HDLC-ATC Air Traffic Data Communication Server provides two or three 10 / 100M Ethernet interfaces and four, eight or sixteen synchronous HDLC serial ports (two of which support asynchronous UART) to realize protocol conversion between serial ports and Ethernet ports.

It is used to receive and send synchronous serial data of the ATC primary surveillance radar, secondary surveillance radar and ADS-B and other devices, supporting HDLC and TCP / IP protocol conversion.

1U, 19-inch standard rack chassis, low power consumption, no fan high reliability design, support dual power redundancy.



1.2 Features

- 2, 3-way 10 / 100M Ethernet interface;
- 4, 8, 16 HDLC synchronous RS-232 serial port, 2 of which support asynchronous UART;
- 1U, 19-inch standard rack chassis;
- Dual power supply redundancy;
- Low power consumption, no fan design.

1.3 Application

- Serial port to Ethernet;
- Ethernet to serial port;
- Single serial port forwarding to multiple, ATC radar signal splitter;
- Air traffic control primary surveillance radar (PSR), secondary surveillance radar (SSR), ADS-B target reporting lead and output;
- Air Traffic Control (ATC), Air Traffic Management (ATM);
- ATC radar data record and playback;
- Rack-Mounted application.

1.4 Technical Specifications

Item	Parameters	Details
Serial Port	Quantity	4, 8, 16 x RJ-45
	Working mode	Synchronous HDLC, Asynchronous UART
	Interface type	RS-232 full-duplex
	Encoding format	NRZ
	Baud rate	≤ 250 Kbps
	Synchronous clock	General, Master, Slave(external clock)
	ESD protection	± 15 KV
Ethernet Interface	Quantity	2, 3 x RJ-45
	Rate	10/100 Mbps, supporting MDI / MDIX adaptation
	Protocol	TCP/IP
	Programming interface	UDP Server, UDP Client
Configuration Management	Configuration tool	yacer-DMS configuration management software
	Console interface	Ethernet Interface
Power Requirements	Power redundancy	Dual AC redundancy (AC1 priority)
	AC power supply	85 ~ 265VAC
	DC power supply	9 ~ 36VDC
	Power consumption	< 10 W
Mechanical Characteristics	Dimensions	1U, standard 19-inch rack mounted, fanless design
	Weight	3.0 Kg
Operating Environment	Operating temperature	-10 ~ +60°C
	Storage temperature	-30 ~ +75°C
	Operating humidity	30 ~ 90% RH (no condensation)
	Storage humidity	10 ~ 90% RH (no condensation)

1.5 Order Information

Product Model	Serial Port	Ethernet Interface	Power Redundancy
HDLC-ATC-400	4 x RS-232 synchronous serial port, two of which support asynchronous	2 x 10/100M	Dual AC
HDLC-ATC-800	8 x RS-232 synchronous serial port, two of which support asynchronous	2 x 10/100M	Dual AC
HDLC-ATC-1600	16 x RS-232 synchronous serial port, two of which support asynchronous	3 x 10/100M	Dual AC

2 Hardware and Physical Interface

2.1 Chassis and panels

The chassis is 19 inch standard chassis and 1U high.

The front panel includes 4, 8 and 16 serial interfaces (S1 ~ S16), 2 and 3 Ethernet interfaces (ETH1 ~ ETH3), and RJ-45 connector is used for serial and Ethernet interfaces.

The rear panel includes:

- Power switch;
- AC power socket: 110V / 220V AC power input, with fuse;
- DC power socket: 9 ~ 36VDC input, on-board self-recovery fuse;
- Grounding stud.



2.2 LED Indicators

LED	Color	Description
ALARM	RED	Alarm indicator flashes during initialization, light on during operation indicates equipment failure
RUN	GREEN	Running indicator, flashing green during normal operation
POWER	GREEN	Power indicator, always on after power on
MAIN	GREEN	Light on, it indicates that main power supply Light off, it indicates that standby power supply

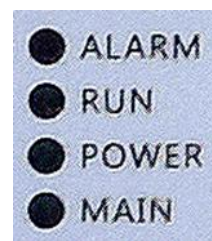

2.3 Ethernet Interfaces

Two or three 10/100M Ethernet RJ-45 interface supports MDI/MDIX adaptive.

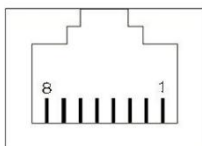
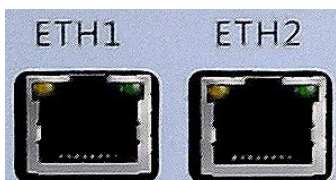

RJ45 Pin	Description
1	Tx +
2	Tx -
3	Rx +
6	Rx -

2.4 Serial Interface

Provides 4, 8, 16 RS-232 synchronous or asynchronous serial ports, support HDLC protocol, using RJ-45 connector. Each RJ45 interface has two indicator lights, the yellow light flashes to indicate data sending and the green light flashes to indicate data receiving.

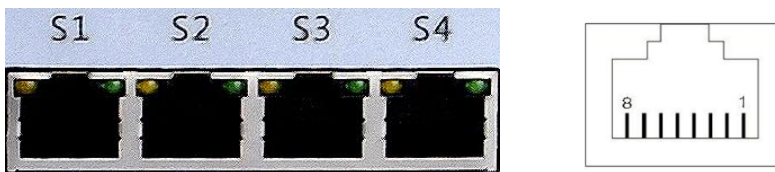

RJ45 Pin	RS-232	Type	Description
1	GND		Ground
2	TxData	Out	Send Data
3			
4	TxClock	Out	Send Clock
5			
6	RxData	In	Receive Data
7			
8	RxClock	In	Receive Clock

3 Building Configuration Environment

3.1 Connect the configuration computer with HDLC-ATC

Connect the management computer with any Ethernet interface port of HDLC-ATC through network cable, and run yacer-DMS configuration management software on the computer to configure the parameters and monitor running status of HDLC-ATC.

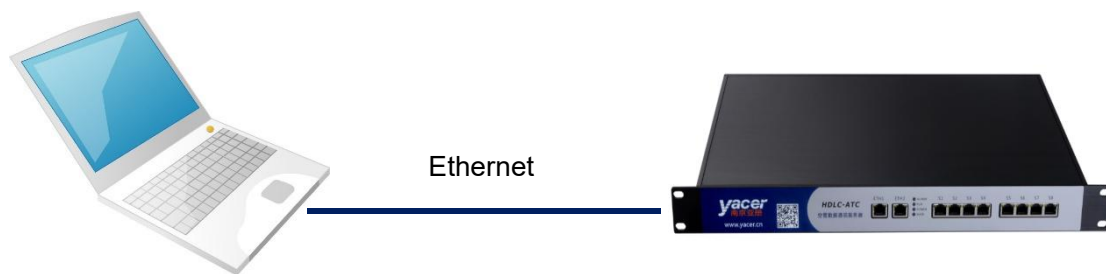

3.2 Get configuration management software yacer-DMS

Users can obtain the compressed package yacer-DMS.zip of configuration management software through the following ways:

- Software & Tools directory of HDLC-ATC accompanied U-Disk;
- Official website of Yacer (<http://www.yacer.com.cn>) Software channel.

3.3 Run yacer-DMS software

The yacer-DMS is an installation free application software, unzip yacer-DMS.zip, enter the working directory and double click the file yacer-DMS.exe to run.

3.4 Main Window of yacer-DMS

The following figure is the main interface of the configuration management software, which can be divided into three parts:

- Toolbar: Functional operation buttons;
- Device List: Displaying the basic information and operation status of online devices;
- Statistical Report: Displaying the receive/transmit indication & statistics, and device details.

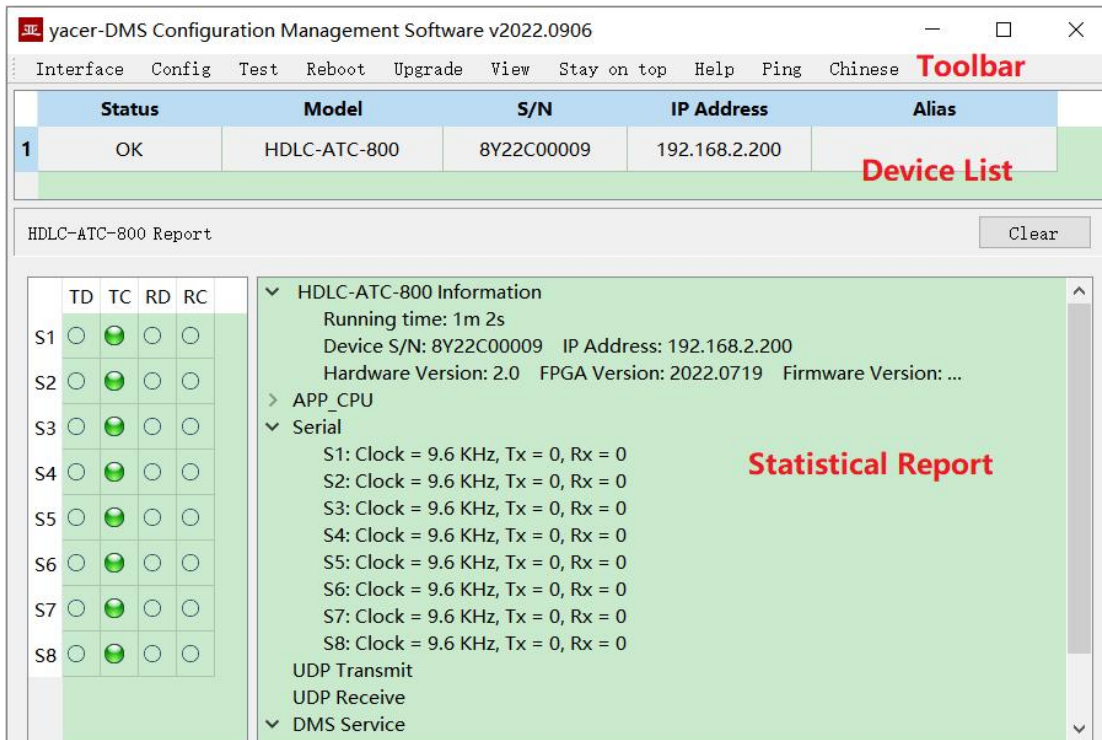

3.5 Statistical Report

The statistical report has three panels: control panel, receive/transmit indication panel and information panel.

3.5.1 Control Panel

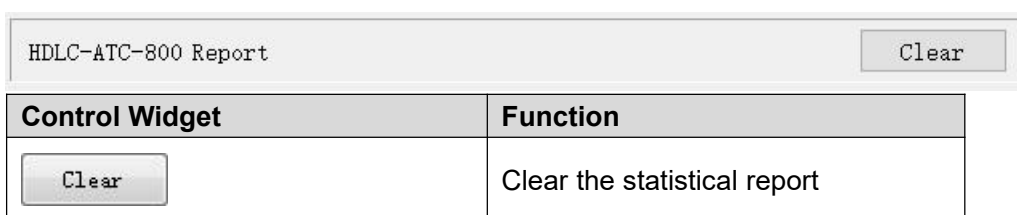

3.5.2 Receive/Transmit Indication Panel

3.5.2.1 HDLC-ATC-400

- Tx: The interface sends a frame of data, corresponding Tx indicator blinks once;
- Rx: The interface receives a frame of data, corresponding Rx indicator blinks once.

	Tx	Rx
S1	<input checked="" type="checkbox"/>	<input type="checkbox"/>
S2	<input type="checkbox"/>	<input checked="" type="checkbox"/>
S3	<input type="checkbox"/>	<input type="checkbox"/>
S4	<input type="checkbox"/>	<input type="checkbox"/>

3.5.2.2 HDLC-ATC-800, HDLC-ATC-1600

- TD: Blinking when there is a pulse signal on the sending data line;
- TC: Blinking when there is a pulse signal on the sending clock line;
- RD: Blinking when there is a pulse signal on the receiving data line;
- RC: Blinking when there is a pulse signal on the receiving clock line.

	TD	TC	RD	RC
S1	<input checked="" type="checkbox"/>	<input checked="" type="checkbox"/>	<input type="checkbox"/>	<input type="checkbox"/>
S2	<input type="checkbox"/>	<input checked="" type="checkbox"/>	<input type="checkbox"/>	<input type="checkbox"/>
S3	<input checked="" type="checkbox"/>	<input checked="" type="checkbox"/>	<input type="checkbox"/>	<input type="checkbox"/>
S4	<input type="checkbox"/>	<input checked="" type="checkbox"/>	<input type="checkbox"/>	<input type="checkbox"/>
S5	<input type="checkbox"/>	<input checked="" type="checkbox"/>	<input type="checkbox"/>	<input type="checkbox"/>
S6	<input type="checkbox"/>	<input checked="" type="checkbox"/>	<input type="checkbox"/>	<input type="checkbox"/>
S7	<input type="checkbox"/>	<input checked="" type="checkbox"/>	<input type="checkbox"/>	<input type="checkbox"/>
S8	<input type="checkbox"/>	<input checked="" type="checkbox"/>	<input type="checkbox"/>	<input type="checkbox"/>

3.5.3 Information Panel

The right side of the statistical report is the information panel, which can display the following contents:

- Device information: Running time, S/N, IP address and Version number;
- Serial: Receive/transmit statistics of all serial ports;
- UDP Send: Send packets of the UDP Client for each enabled serial port to UDP entry;
- UDP Receive: Received packets of UDP server for each enabled UDP to serial port entries;
- DMS Service: DMS message receive/transmit statistics.

3.6 Configure Device

Click the 'Config' button on the toolbar or double-click the selected device in the device list, DMS pops up the configuration dialog. According to the interface and function, the dialog divides the configuration items into several configuration pages.

The bottom of the dialog box includes the following operation buttons:

Button	Function
Import	Open the configuration file, read the configuration parameters refresh the configuration dialog
Export	Export configuration parameters from the configuration dialog to a file for saving
Restore Defaults	Refresh the configuration dialog with the factory paramters
Apply and Reboot	Write the configuration parameters in the dialog to the deivce, and restart the device to make the configuration take effect
Cancel	Cancel current configuration operation

4 Function and Configuration

4.1 Ethernet Interface

4.1.1 Device alias

Allow users to set aliases for HDLC-ATC to add descriptions or mnemonic identities to the device.

The screenshot shows a configuration window with tabs for 'Ethernet', 'Serial', 'UDP-Serial', 'Serial-UDP', and 'Serial-Serial'. The 'Ethernet' tab is selected. Below the tabs, there is a label 'Device Alias:' followed by an empty text input field.

4.1.2 IP configuration

4.1.2.1 Enable Ethernet switch

By default, check the “Enable ethernet switch” checkbox to enable the built-in Ethernet switch, to provide Ethernet switching function between ETH1 and ETH2.

Enable ethernet switch

	IP Address	Subnet Mask	Default Gateway
ETH1	192.168.2.200	255.255.255.0	0.0.0.0

After enabling the Ethernet switching function, HDLC-ATC only has one IP address. The network functions are as follows:

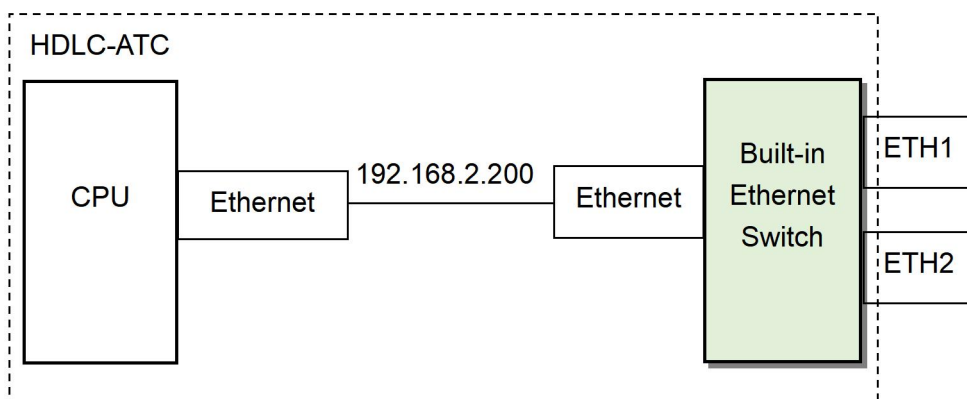

4.1.2.2 Dual IP Configuration

When the “Enable ethernet switch” checkbox is unchecked, ensure ETH1 and ETH2 are not on the same subnet for configuration as they have an independent IP address.

Enable ethernet switch

	IP Address	Subnet Mask	Default Gateway
ETH1	192.168.2.200	255.255.255.0	0.0.0.0
ETH2	0.0.0.0	0.0.0.0	0.0.0.0

With the dual-IP function figure as follows, the HDLC-ATC is equivalent to a PC equipped with two network cards.

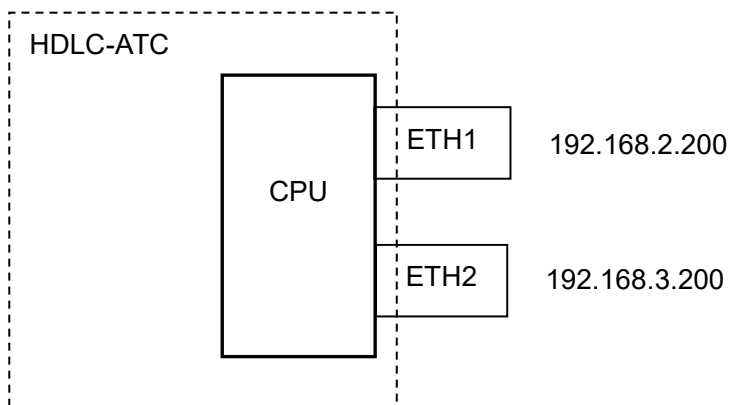

4.1.3 Default Gateway

By default, the default gateway is 0.0.0.0, representing that there is no gateway configuration.

If HDLC-ATC needs to communicate with the host on other subnet, it must rely on an external router. At this time, the HDLC-ATC's IP address must be on the same subnet with the IP address of the connected router port. Meanwhile, the IP address of router is set to the default gateway.

As shown below, the IP address of HDLC-ATC and remote PC is 192.168.2.200 and 192.168.5.100 respectively. As they do not belong to the same subnet, they must rely on the router for communication. HDLC-ATC and PC need to set the IP address of the connected router port to the default gateway of this device.

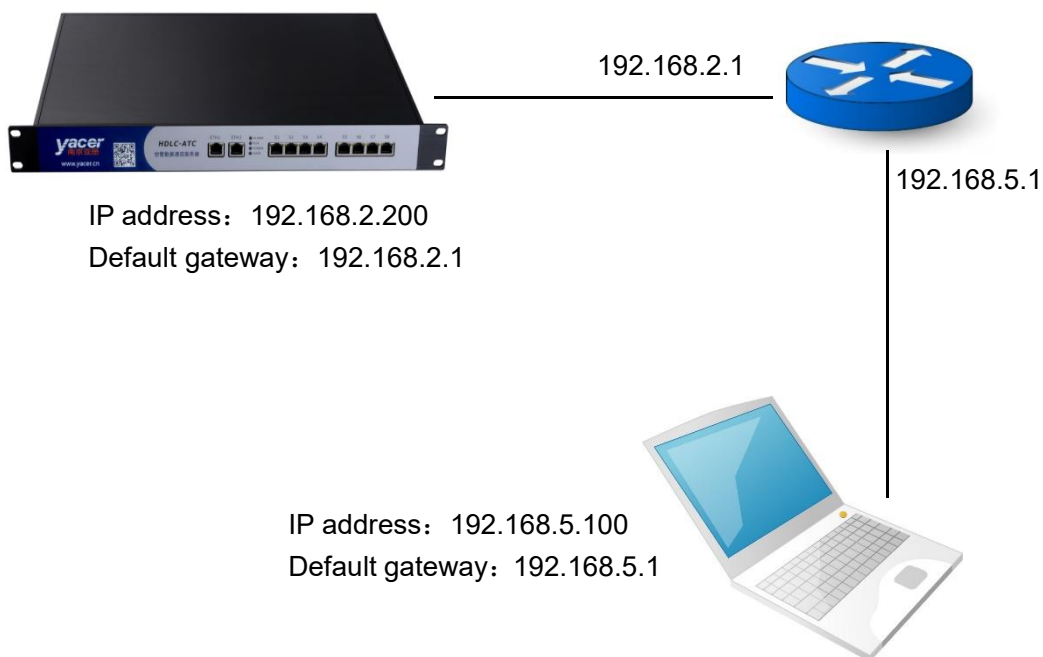

4.1.4 Announce Configuration

HDLC-ATC can actively send notification data to the management computer to provide converter operation information, data communication transceiver statistical reports.

Announce

Destination IP Address:

Destination UDP Port:

Status Period: seconds (1 - 255, 0 = no announce)

Statistics Period: seconds (1 - 255, 0 = no announce)

The notification settings include the following parameters:

Parameter	Description
Destination IP address	The notification message is sent to the destination IP, which can be unicast or multicast address
Destination UDP port	The notification is sent by UDP message. The purpose UDP port number can be set.
Device information notification cycle	Sending period of device operation information notification, 1 ~ 255 seconds
Statistical report notification cycle	Sending cycle of statistical reports, 1~255 seconds

4.2 Serial Port

4.2.1 Working mode of the serial port

All serial ports support synchronous HDLC working mode, only 2 serial ports support asynchronous working mode at the same time.

Working Mode		Description
Synchronous	HDLC-NRZ	Synchronous HDLC protocol based on NRZ encoding
Asynchronous	UART	Universal asynchronous serial mode, similar to serial port on a universal computer
	UART-PPP	Frame transfer on UART interface using PPP protocol

Users can select the desired working mode from the “working mode” combo box. Due to different parameter configurations of each working mode, the contents of the “Options” cell will be adjusted automatically according to the determined working mode.

If you need to further more configuration of working parameters for the selected working mode, double-click on the “Options” cell to pop up the parameter configuration dialog.

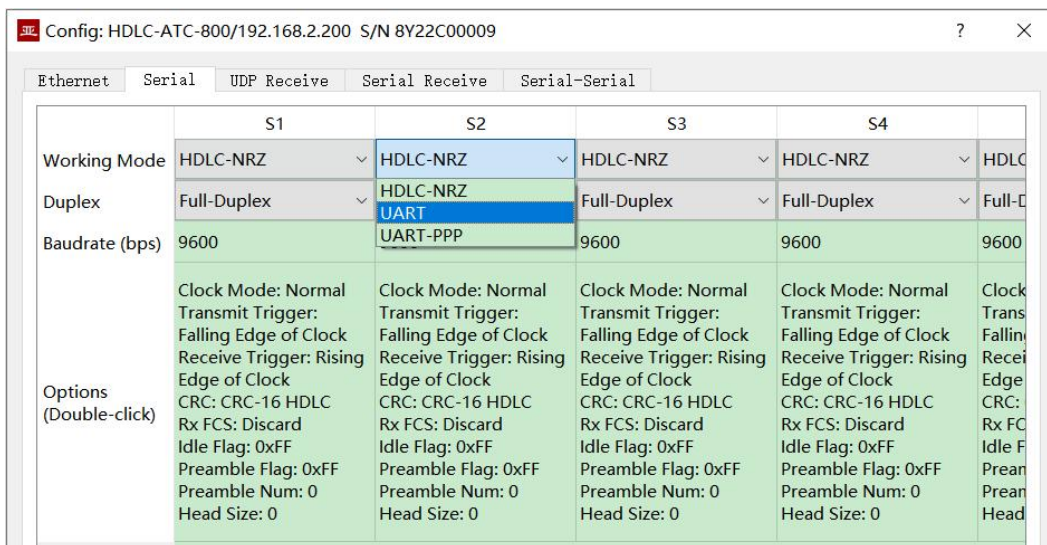

4.2.2 HDLC-NRZ Parameter Configuration

HDLC-NRZ is the common synchronous working mode, which is mainly used for the secondary surveillance radar and ADS-B data communication in air traffic control (ATC) and air traffic management (ATM) fields.

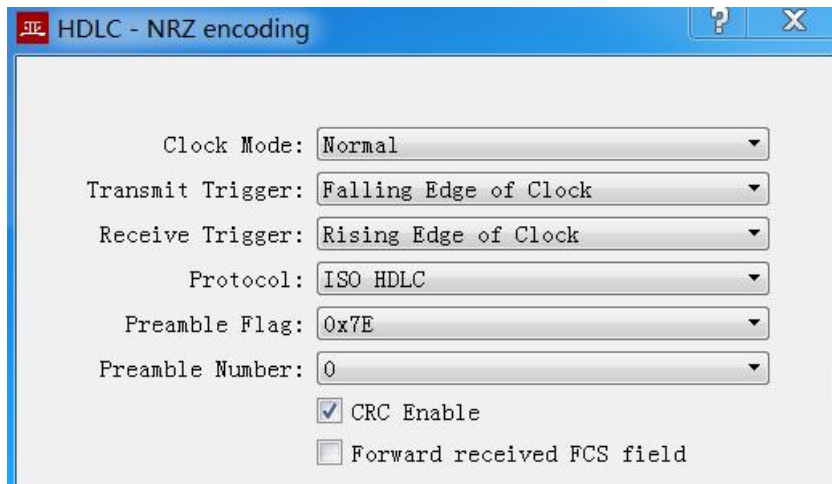

4.2.2.1 Clock Mode

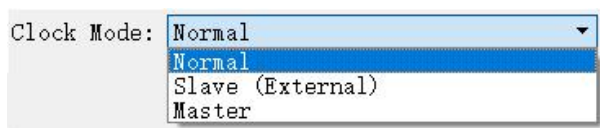

There are three clock modes for the synchronous serial port, normal, slave clock and master clock.

Clock Mode	Transmit Clock	Receive Clock
Normal	Local device generated, output via pin TxC	Opposite device generated, input via pin RxC
Slave(External)	Opposite device generated from pin RxC. TxC output synchronizes with RxC automatically.	Opposite device generated, input via pin RxC
Master	Local device generated, output via pin TxC	Local device generated, ignore pin RxC input

Slave clock mode is also called external clock mode. When the opposite side is the transmission device, HDLC-ATC is often configured to slave clock mode, sending data with the clock provided by the transmission device to ensure that the data transmission in the whole network is based on the same clock, avoiding the hidden danger of packet loss caused by different clock sources.

4.2.2.2 Transmit Trigger

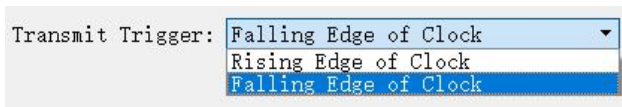

Transmit trigger defines the generation time of new data bit:

- Falling edge of clock: Generate new data bits at the falling edge of clock;
- Rising edge of clock: Generate new data bits at the rising edge of clock.

In ATC communication, the falling edge of the clock is generally selected to trigger new data transmission.

4.2.2.3 Receive Trigger

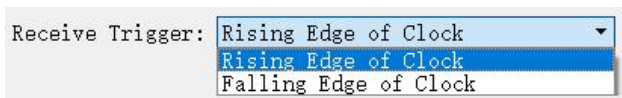

Receive trigger defines the sampling time of serial receiving data:

- Rising edge of clock: Read data on the RxD line at the rising edge of RxC signal;
- Falling edge of colck: Read data on the RxD line at the falling edge of RxC signal.

In ATC communication, because the new data is triggered by the falling edge, considering the stability time of the new data, in order to ensure the correct reading of the data, the receive trigger must be configured as the clock rise edge.

The receive trigger configuration should be determined according to the transmit trigger of the opposite device:

Opposite Transmit Clock	Local Receive Clock
Falling edge of clock	Rising edge of clock
Rising edge of clock	Falling edge of clock

4.2.2.4 CRC

In ATC communication, CRC-16 HDLC mode is generally selected, which is based on ISO HDLC protocol standard for CRC verification.

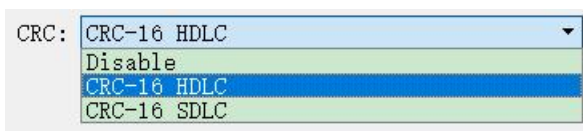

4.2.2.5 Forward Received FCS Field

This configuration only takes effect when CRC enabled.

Forward received FCS field

HDLC frame structure is shown in the following table, where FCS is the frame check sequence field.

By default, this option is unchecked, HDLC-ATC discards the FCS field of 2/4 bytes at the end of the data and forwards only user data after receiving the HDLC frame and passing the CRC check.

If the check box is checked, the user data + FCS field is forwarded.

Opening Flag	Address Field	Control Field	Information Field	FCS Field	Closing Flag
0x7E	1 Byte	1 Byte	Variable length	CRC 2 bytes	0x7E
0x7E	User data			CRC 2 bytes	0x7E

4.2.2.6 Idle Flag

Based on the HDLC protocol, HDLC-ATC uses continuous 1 as the inter-frame idle flag and defaults to 0xFF.

4.2.2.7 Preamble Flag and Number

In half-duplex communication, it is often necessary to add a preamble flag in front of the frame for receiver synchronization. The most common is to add 2-5 0x7E preamble flag.

ATC communication often uses full duplex applications, there is often no need for a preamble flag, just set the number of preamble to 0 (no preamble).

4.2.2.8 Frame Head Length and Content

The above figure is taken as an example. The length of frame head is defined as 2, and the content of frame head is defined as FF 03 in hexadecimal:

- HDLC send: add FF 03 before user data to make up HDLC frame data with user data;
- HDLC Receive: HDLC-ATC discards the first two bytes of HDLC frame data as a header and forwards only subsequent data to the user.

Opening Flag	Flame Header	User Data	FCS Field	Closing Flag
0x7E	0xFF 0x03	Variable length	CRC 2/4 bytes	0x7E

4.2.3 UART Options

UART is a type of character stream communication. Data bits, parity bits and stop bits define the basic working parameters of the asynchronous serial port, which must be identical to the configuration of opposite device.

Generally, Data bits are defined as 8 bits (1 byte), so that UART corresponds to the communication of byte streams.

Data Bits: 8
Parity Bits: None
Stop Bits: 1
Rx Packing Size: 128 bytes
Rx Packing Interval: 10 ms

When converting the byte stream of UART into UDP message or HDLC frame, if every byte is converted into a UDP message for transmission, the overhead is too large and the efficiency is too low.

In order to improve the efficiency, HDLC-ATC will buffer the received byte stream, and then send out a UDP message composed of several buffered bytes. This process is called packing.

Packing is controlled by two parameters, which are called Packing Size & Packing interval.

4.2.3.1 Packing Size

For example, if the Packing Size is set to 128 bytes, then when UART receives 128 bytes, a packet will be formed for forwarding.

Rx Packing Size: 128 bytes

4.2.3.2 Packing Interval

For example, the above example sets the Packing Interval to 10ms. If the UART does not receive new data after 10ms, the data in the buffer will be forwarded as a packet regardless of whether 128 bytes are received.

Rx Packing Interval: 10 ms

4.2.4 UART-PPP Options

The UART-PPP working mode is a customized protocol by Yacer which form the asynchronous HDLC frame on the basis of the normal UART communication by packaging the byte stream. Therefore, the asynchronous serial port can perform the packet-based communication with the UDP message and synchronous HDLC frame.

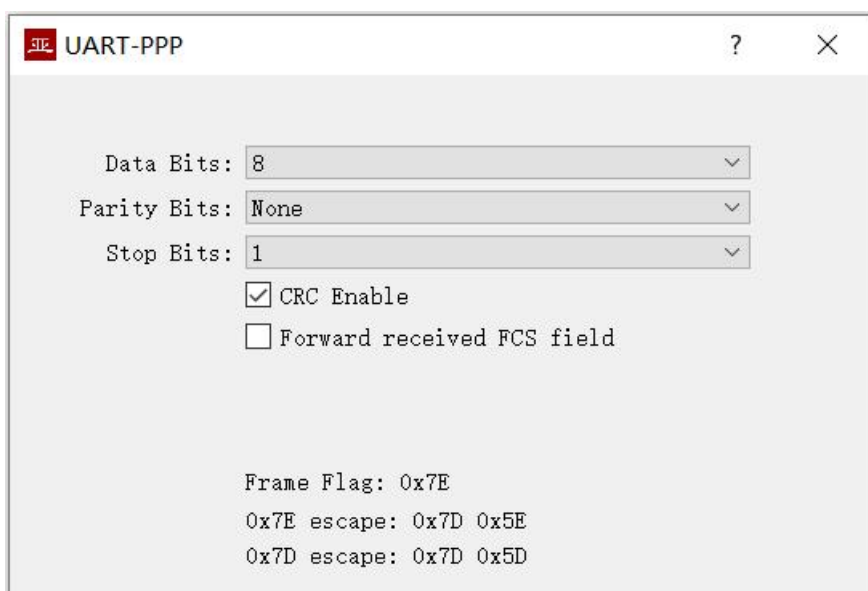

The UART-PPP frame format adds 0x7E before and after the packet as the opening flag closing flag with the frame structure as follows:

Opening Flag	Information Field	FCS Field	Closing Flag
0x7E	2-1470 bytes	2 bytes CRC	0x7E

As the information field and FCS field may appear 0x7E, perform the character escape on such fields before transmission with the escape rules as follows:

- 0x7E: Escaped to two characters, 0x7D 0x5E;
- 0x7D: Escaped to two characters, 0x7D 0x5D;
- Other characters: No escape.

The escape operation of data send is as follows:

Original Data	Actual Transmit Data
0x7E	0x7D 0x5E
0x7D	0x7D 0x5D
Others	No change

The escape operation of data receive is as follows:

Original Data	Actual Transmit Data
0x7D 0x5E	0x7E
0x7D 0x5D	0x7D
Others	No change

4.3 UDP to Serial

4.3.1 Function Description

With HDLC-ATC, a PC or server can realize the data send function of the synchronous HDLC or UART.

The typical application is shown as follows. PC sends a UDP message over the Ethernet interface as the UDP Client, and HDLC-ATC sends it out from the synchronous serial port after converting the received UDP message into the HDLC frame.

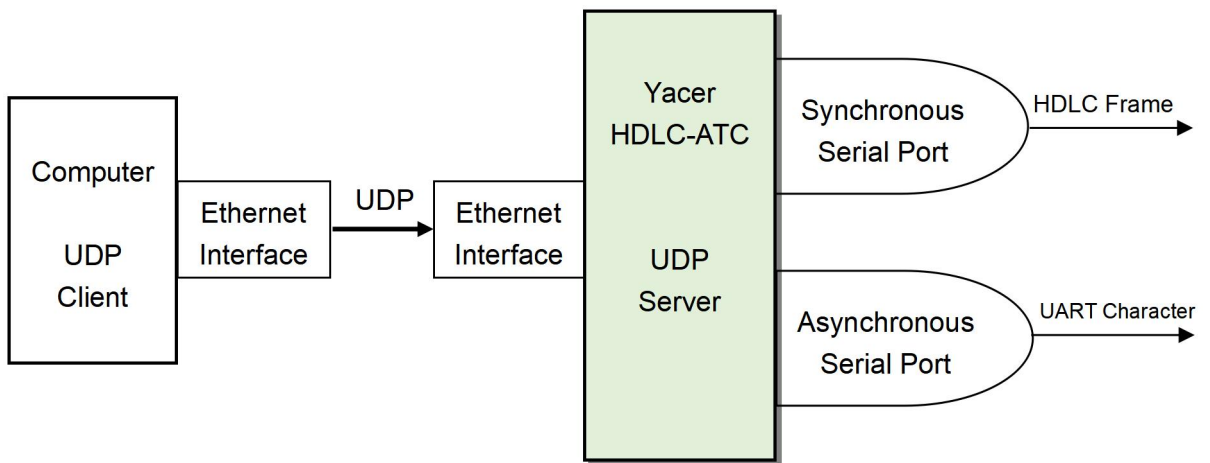

4.3.2 Protocol Conversion

The most typical application of UDP to HDLC is shown in the figure below. HDLC-ATC loads UDP application data into the user data area of HDLC frame, then calculates CRC and fills FCS field to form a complete HDLC frame for sending.

In order to reduce the computational load of the computer and the complexity of user programming, generally, the UDP message does not contain the FCS field of HDLC, which is calculated and filled by HDLC-ATC.

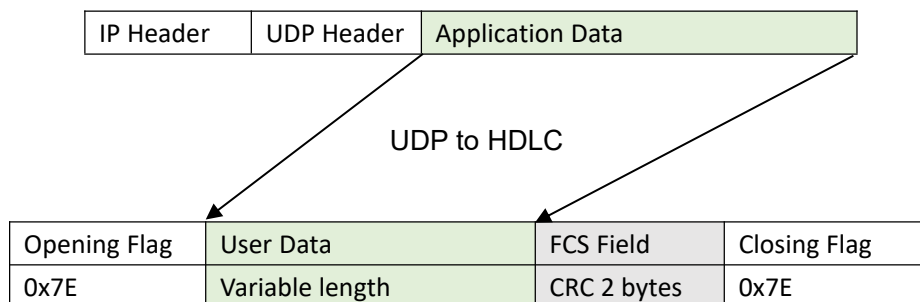

4.3.3 Forwarding Configuration

Set UDP to serial ports, each line represents a UDP port to serial forwarding entry. Three forwarding strategies can be implemented:

- Forwarding: Data received by the specified UDP port can be forwarded to the specified serial port;
- Convergence: Data received by multiple different UDP ports can be forwarded to the same serial port;
- Branch: Data received from the UDP port can be forwarded to multiple serial ports at the same time.

Ethernet		Serial		UDP Receive		Serial Receive		Serial-Serial	
Local Rx UDP Port	Forward to	Egress Serial	Rx Multicast Address						
1	8001	enable	Serial-S1	Group-1	0.0.0.0				
2	8002	enable	Serial-S2	Group-2	0.0.0.0				
3	8003	enable	Serial-S3	Group-3	0.0.0.0				
4	8004	enable	Serial-S4	Group-4	0.0.0.0				
5	0	disable	Serial-S1	Group-5	0.0.0.0				
6	0	disable	Serial-S2	Group-6	0.0.0.0				
7	0	disable	Serial-S3	Group-7	0.0.0.0				
8	0	disable	Serial-S4	Group-8	0.0.0.0				
				(224.0.0.0 - 239.255.255.255)					
				<input type="checkbox"/> Report serial TxFiFo usage					

The following configuration implements an application that receives data from a UDP port and distributes it to eight serial ports simultaneously:

Ethernet		Serial		UDP Receive		Serial Receive		Serial-Serial	
Local Rx UDP Port	Forward to	Egress Serial	Rx Multicast Address						
1	8000	enable	Serial-S1	Group-1	0.0.0.0				
2	8000	enable	Serial-S2	Group-2	0.0.0.0				
3	8000	enable	Serial-S3	Group-3	0.0.0.0				
4	8000	enable	Serial-S4	Group-4	0.0.0.0				
5	0	disable	Serial-S1	Group-5	0.0.0.0				
				Group-6	0.0.0.0				

4.3.4 Receive Multicast

If users need to receive a multicast UDP message, add the required multicast address to the "Rx Multicast Address" list on the right.

Range of the multicast address is 224.0.0.0 ~ 239.255.255.255, 224.8.8.8 is the configuration management address for HDLC-ATC and cannot be used by users.

The multicast address configured as 0.0.0.0 indicates that the entry is not valid.

4.4 Serial to UDP

4.4.1 Function Description

The schematic diagram of serial port to UDP function is as follows. HDLC-ATC receives HDLC frames or UART data from other device through serial interface, converts them into UDP messages, and sends the messages to computers or servers through Ethernet.

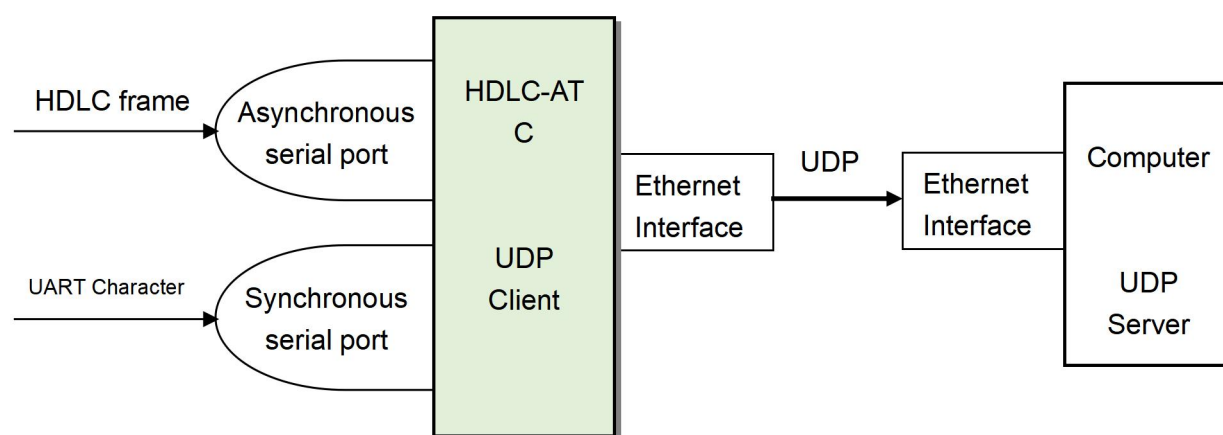

4.4.2 Protocol Conversion

To ensure the integrity of user data, HDLC-ATC places complete HDLC frames in UDP application data and forwards them to UDP Server.

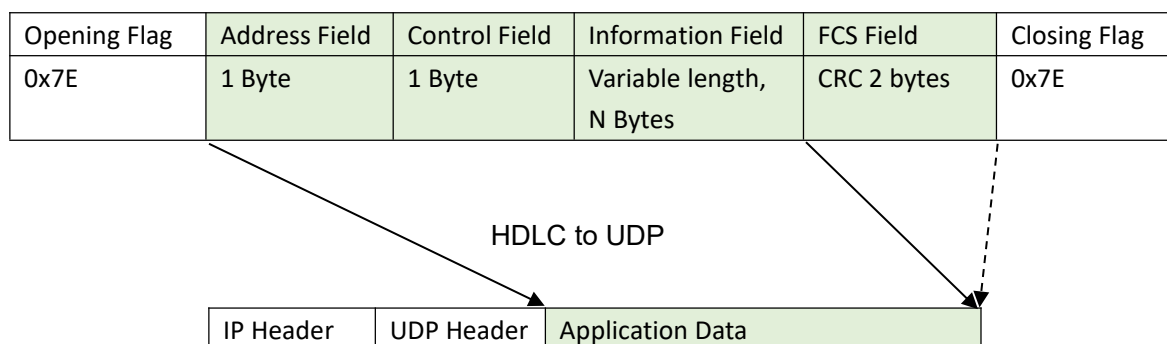

4.4.3 Forwarding Configuration

Set serial ports to UDP, each line represents a serial to UDP port forwarding entry. Three forwarding strategies can be implemented

- Forwarding: Data received from the specified serial port can be forwarded to the specified destination IP + UDP port;
- Convergence: Data received from multiple different serial ports can be forwarded to the same destination IP + UDP port;
- Branch: Data received from the serial port can be forwarded to multiple destination IP or UDP port at the same time.

	Ethernet	Serial	UDP Receive	Serial Receive	Serial-Serial
		Ingress Serial	➔ Forward to	Remote Rx IP Address	Remote Rx UDP Port
1		Serial-S1	➔ enable	192.168.2.80	8000
2		Serial-S2	➔ enable	255.255.255.255	9000
3		Serial-S3	➔ enable	224.10.10.10	10000
4		Serial-S1	✗ disable	0.0.0.0	0
5		Serial-S1	✗ disable	0.0.0.0	0
		Serial-S2	✗ disable	0.0.0.0	0
6		Serial-S3	✗ disable	0.0.0.0	0
		Serial-S4	✗ disable	0.0.0.0	0
7		Serial-S1	✗ disable	0.0.0.0	0
8		Serial-S1	✗ disable	0.0.0.0	0

As shown in the figure above, three Serial to UDP entries are configured to implement:

- Serial port S1 to UDP unicast, destination IP address 192.168.2.80 and destination UDP port 8000;
- Serial port S2 to UDP broadcast, all hosts in the network can receive data from S2 at port 9000;
- Serial port S3 to UDP multicast, only computers joined 224.10.10.10 groups in the network can receive data from S3.

4.4.4 How UDP Server identifies Source Serial ports

In many applications, such as air traffic control automation (ATC) applications, HDLC frames originating from multiple different serial ports need to be forwarded to a server or computer for uniform processing. In this case, a strategy is needed to let the computer know which serial port the UDP message is received from.

4.4.4.1 Identify Source Serial Port Based on Destination UDP Port

As shown in the figure below, set different forwarding destination UDP ports for each serial port. As a UDP Server, computer receives data on different UDP ports: the message received on port 8001 comes from serial port S1, and the message received on port 8002 comes from serial port S2.

Ethernet		Serial		UDP Receive		Serial Receive		Serial-Serial	
	Ingress Serial		➔ Forward to		Remote Rx IP Address		Remote Rx UDP Port		
1	Serial-S1	▼	➔ enable ▼	▼	192.168.2.80		8001		
2	Serial-S2	▼	➔ enable ▼	▼	192.168.2.80		8002		
3	Serial-S3	▼	➔ enable ▼	▼	192.168.2.80		8003		
4	Serial-S4	▼	➔ enable ▼	▼	192.168.2.80		8004		

4.4.4.2 Identify Source Serial Port Based on Source UDP Port

UDP Server needs to listen and receive data on multiple UDP ports when using the destination UDP port to identify the source serial port scheme. When the number of serial ports is large, not only does UDP Server consume too much port resources, but also the complexity of configuration and programming increases a lot.

To simplify the implementation of the UDP Server side, we can forward each transformation to the same port of the UDP Server using the configuration shown below. *Yacer HDLC-ATC automatically adjusts the source port number of UDP message according to the source serial port when forwarding, where serial port S1 forwards UDP message with source port 8001 and serial port S2 with 8002, increasing gradually below.*

In this way, UDP Server only needs to listen and receive data on one port (in the example below, 8000), and then differentiate the source serial ports based on the source UDP port. If there are multiple HDLC-ATC, UDP Server can distinguish the source devices through the source IP.

Ethernet		Serial		UDP Receive		Serial Receive		Serial-Serial	
	Ingress Serial		➔ Forward to		Remote Rx IP Address		Remote Rx UDP Port		
1	Serial-S1	▼	➔ enable ▼	▼	192.168.2.80		8000		
2	Serial-S2	▼	➔ enable ▼	▼	192.168.2.80		8000		
3	Serial-S3	▼	➔ enable ▼	▼	192.168.2.80		8000		
4	Serial-S4	▼	➔ enable ▼	▼	192.168.2.80		8000		

4.5 Serial to Serial

Serial to Serial can forward the input data of a specified serial port to the output of other serial ports. It is mainly used for:

- Conversion between synchronous and asynchronous serial ports;
- Serial port splitter: Divide the single serial port data into multiple channels. Unlike the common demultiplexer. Using HDLC-ATC to implement demultiplexer, each serial port can set different baud rate and clock mode, avoiding packet loss caused by clock inconsistency.

	Forward	S1 Egress	S2 Egress	S3 Egress	S4 Egress
S1 Ingress	➔ Forward to	<input type="checkbox"/> Enable	<input checked="" type="checkbox"/> Enable	<input checked="" type="checkbox"/> Enable	<input checked="" type="checkbox"/> Enable
S2 Ingress	➔ Forward to	<input type="checkbox"/> Enable	<input type="checkbox"/> Enable	<input type="checkbox"/> Enable	<input type="checkbox"/> Enable
S3 Ingress	➔ Forward to	<input type="checkbox"/> Enable	<input type="checkbox"/> Enable	<input type="checkbox"/> Enable	<input type="checkbox"/> Enable
S4 Ingress	➔ Forward to	<input type="checkbox"/> Enable	<input type="checkbox"/> Enable	<input type="checkbox"/> Enable	<input type="checkbox"/> Enable

As shown in the above figure, the input of serial port S1 is split to the output of S2, S3 and S4. HDLC-ATC stores and forwards the receiver, even if the baud rate and clock mode of S1, S2, S3 and S4 are different, it will not lose packets.

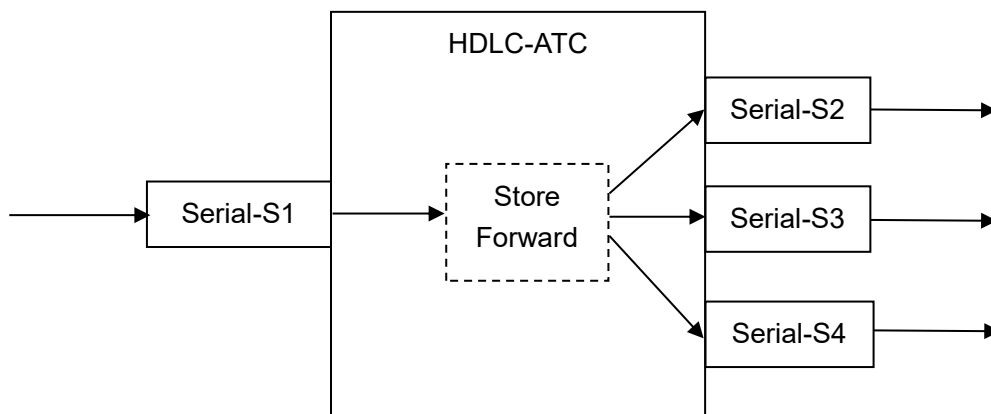

5 System Maintenance

5.1 Firmware Version Upgrade

5.1.1 Start Upgrade

Click the “Upgrade” button on the toolbar to pop up the version upgrade dialog, and then click the “Start” button.

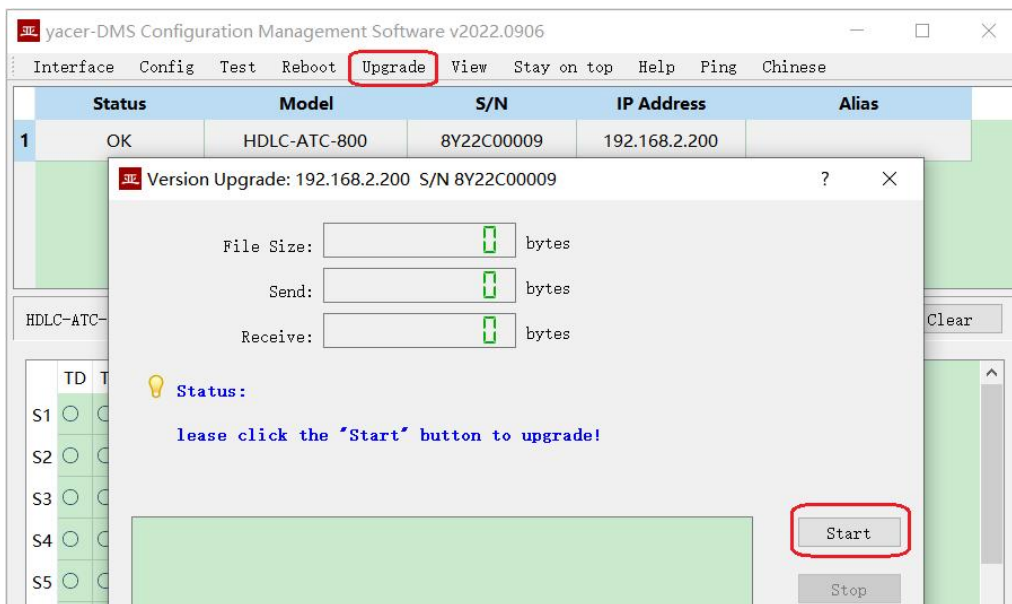

5.1.2 Select Version File

Pop up the “Select version file” dialog, and find the folder where the latest firmware version is stored, select the corresponding file, and click “Open” to start the update.

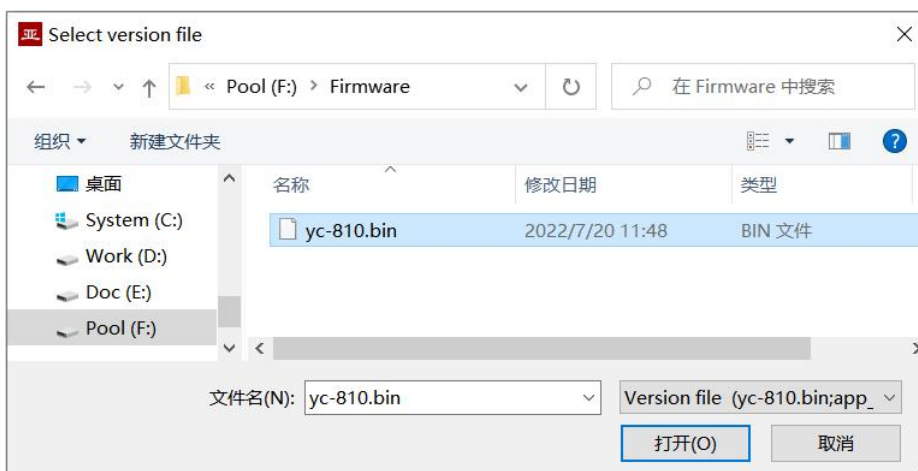

5.1.3 Complete Upgrade

When the page displays “Version upgrade complete” status, it indicates that the version upgrade is completed.

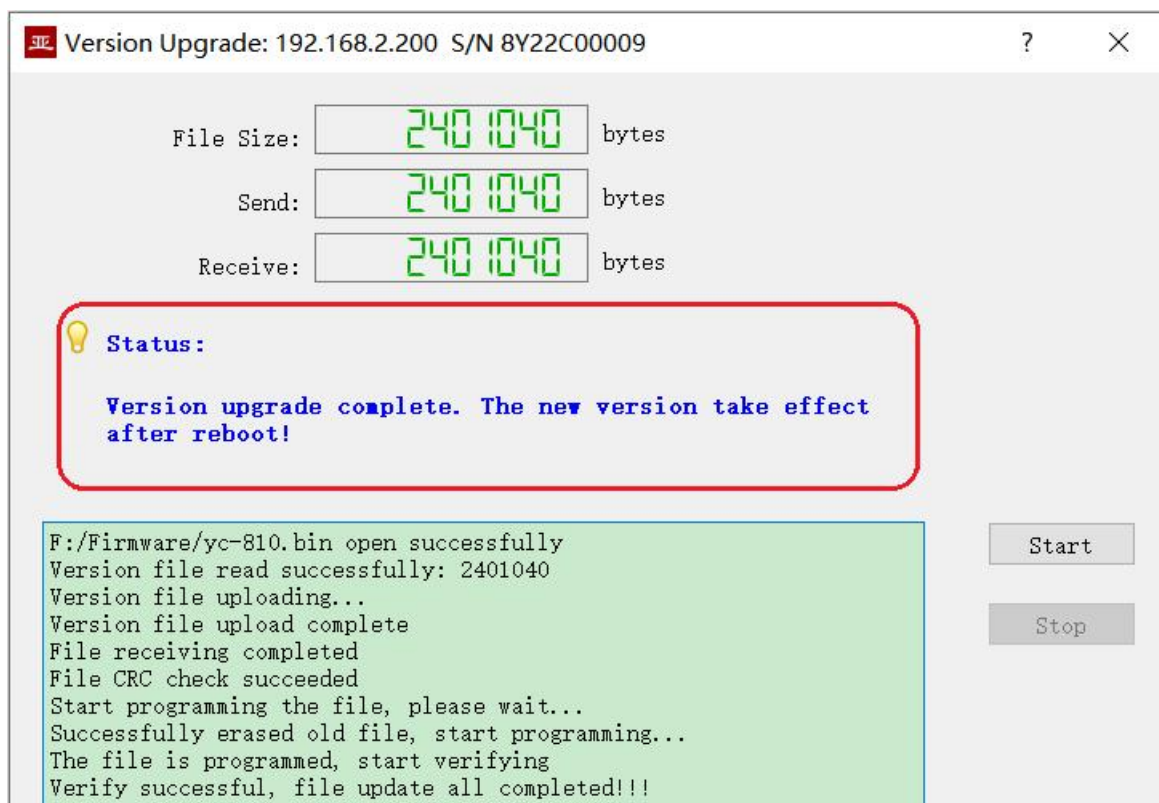

5.1.4 Confirm Upgrade

After the upgrade is completed, power up the device again, observe the version information in the statistical report, and determine whether the new version is successfully updated by the version date.



5.2 Reboot Device

Click the “Reboot” button on the toolbar to pop up the device reboot dialog, and then click the “Reboot” button to reboot the device.

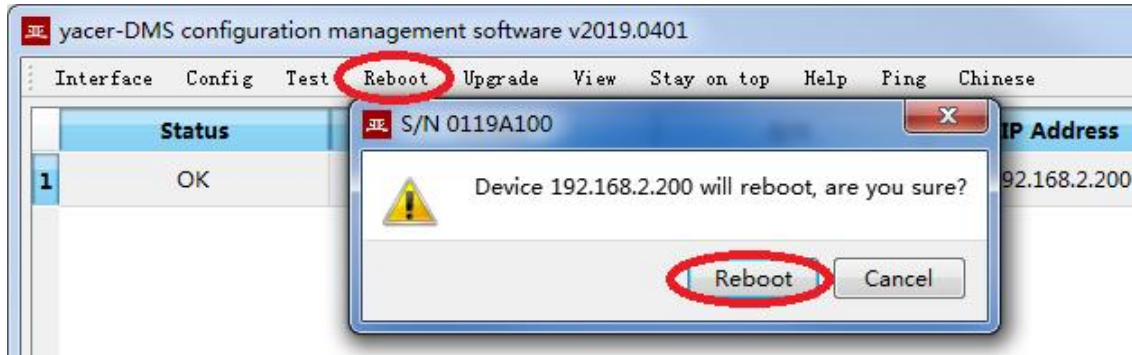

6 Application of Protocol Conversion

6.1 Application Packet and Conversion Model

Serial data conversion includes:

- Protocol conversion between serial port and UDP;
- Data conversion between synchronous and asynchronous serial ports.

At the time of receiving, the receiving processing modules of different types of interfaces perform unpacking or decoding operations on the data, extract the application data packets, and send them to the queue of the system.

The forwarding engine of HDLC-ATC reads the application packet queue and sends it to the sending module of each interface according to the forwarding configuration. The sending module is responsible for the framing or packing operation of the application package to generate different types of protocol packages or data frames and send them through the physical interface.

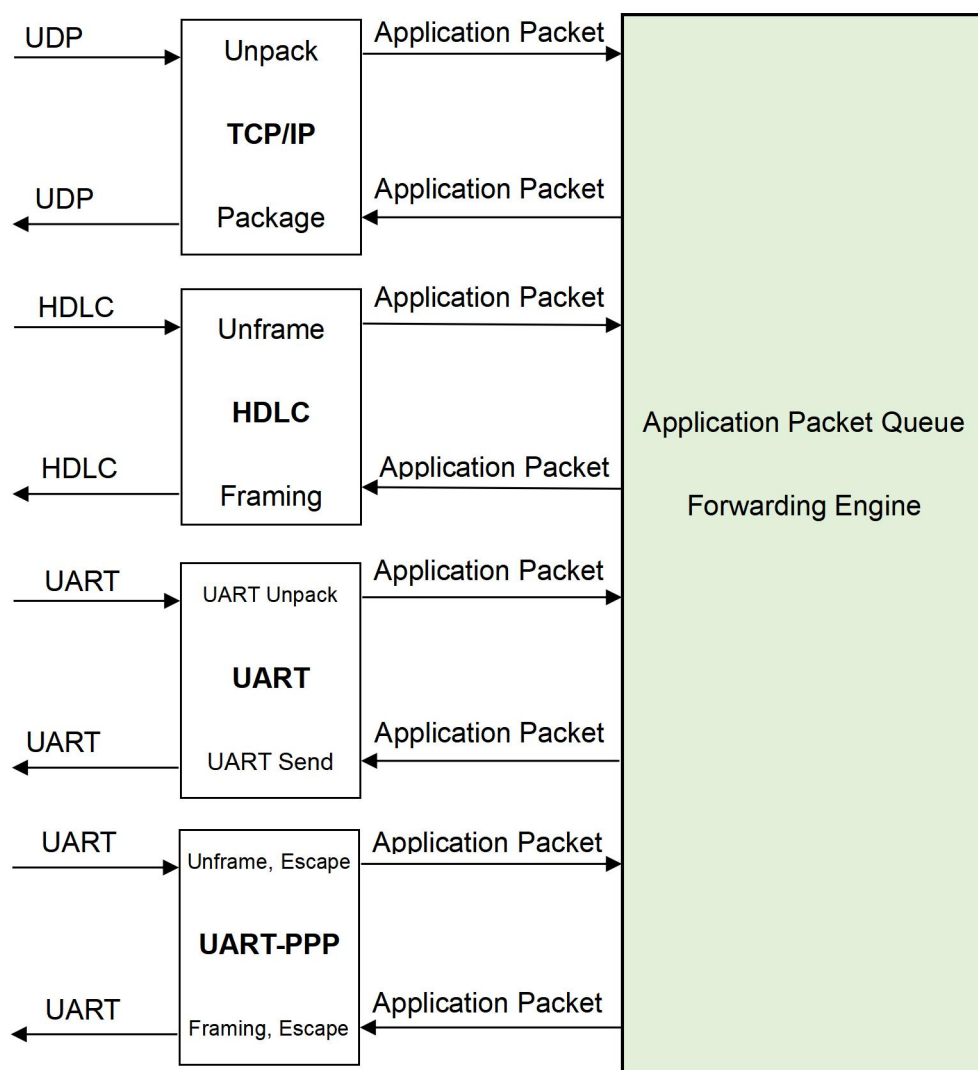

6.2 UDP Message Format

In the UDP protocol, the application packet is packaged in the data area of the UDP message. Each UDP packet contains a complete application packet.

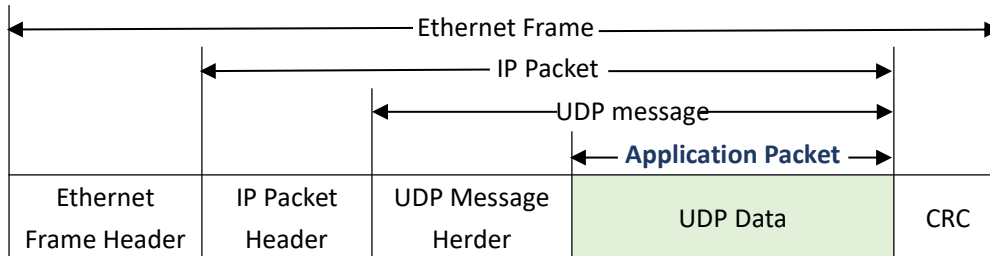

6.3 HDLC Frame Format

A complete HDLC frame consists of several fields between the leading flag and the closing flag, including address field, control field, information field and FCS field for CRC check.

For HDLC-ATC, instead of distinguishing between address field, control field, and information field, they are uniformly presented as application packets to the upper application to fill in and process the UART packet format

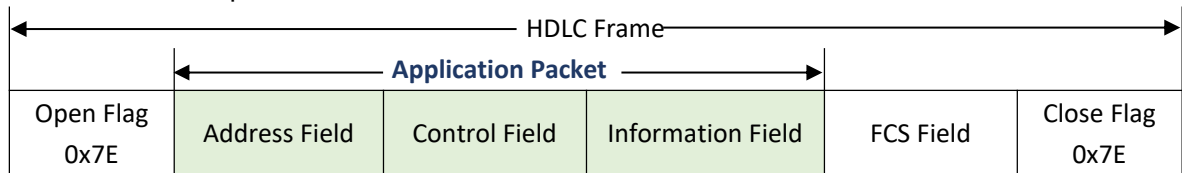

6.4 UART Data Packet

When the serial port is working in the asynchronous UART mode, there is a character stream without head or tail received from the serial port, where there is no information used to perform unpacking or deframing.

HDLC-ATC adopts the time information for unpacking, allowing users to define the packet interval of UART. For example, if the packet interval is 5ms, when no new characters are received over 5ms, then the packet receiving is considered to be complete.

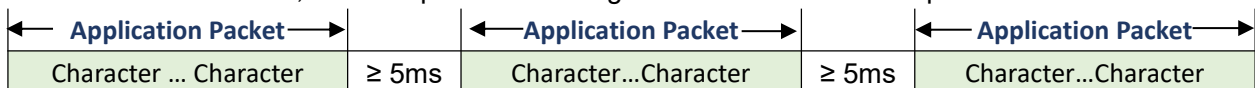

In the actual application, data transmission is not allowed during the packet interval; otherwise, it may result in a waste of communication bandwidth, and the higher the baud rate is, the more serious the waste is.

6.5 UART-PPP Frame Format

The UART-PPP working mode adopts another strategy to provide the unpacking capacity for UART. As shown in the following figure, the data sender calculates the application packet's CRC and adds the 0x7e to the head and tail as the leading and closing flags to form an UART-PPP frame.

This strategy does not require increasing the additional packet interval and can make full use of the communication bandwidth, but increases the processing complexity of both communication sides.

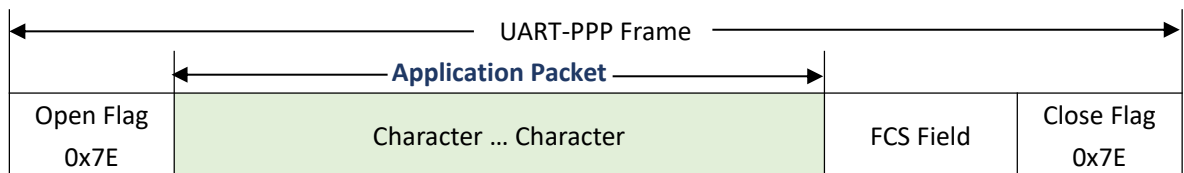

As the information field and FCS field may appear 0x7E, perform the character escape on such fields before transmission with the escape rules as follows:

- 0x7E: Escaped to two characters, 0x7D 0x5E;
- 0x7D: Escaped to two characters, 0x7D 0x5D;
- Other characters: No escape.

The escape operation of data send is as follows:

Original Data	Actual Transmit Data
0x7E	0x7D 0x5E
0x7D	0x7D 0x5D
Others	No change

The escape operation of data receive is as follows:

Original Data	Actual Transmit Data
0x7D 0x5E	0x7E
0x7D 0x5D	0x7D
Others	No change

About the Manual

- The manual is for reference only. If there is inconsistency between the manual and the actual product, the actual product shall prevail.
- We are not liable for any loss caused by the operations that do not comply with the manual.
- All the designs and software are subject to change without prior written notice. The product updates might cause some differences between the actual product and the manual. Please contact the customer service for the latest program and supplementary documentation.
- There still might be deviation in technical data, functions and operations description, or errors in print. If there is any doubt or dispute, we reserve the right of final explanation.
- Upgrade the reader software or try other mainstream reader software if the manual (in PDF format) cannot be opened.
- Please visit our website, contact the supplier or customer service if there is any problem occurring when using the device.
- If there is any uncertainty or controversy, we reserve the right of final explanation.