







# MVB-TCMS

# Datasheet

# Foreword

## Notational Conventions

The following categorized signal words with defined meaning might appear in the manual.

Signal Words	Meaning
 DANGER	Indicates a high potential hazard which, if not avoided, will result in death or serious injury.
 CAUTION	Indicates a potential risk which, if not avoided, could result in property damage, data loss, lower performance, or unpredictable result.
 ANTISTATIC	Indicates static sensitive equipment.
 DANGER! ELECTRIC SHOCK	Indicates High voltage danger.
 TIPS	Provides methods to help you solve a problem or save you time.
 NOTE	Provides additional information as the emphasis and supplement to the text.

# Table of Contents

<b>Foreword</b> .....	<b>I</b>
<b>1 Overview</b> .....	<b>4</b>
1.1 Introduction .....	4
1.2 Applications .....	4
1.3 Features .....	5
1.4 Order Information .....	5
1.5 Function Blocks .....	6
1.6 Technical Specifications .....	7
<b>2 Hardware and Physical Interface</b> .....	<b>9</b>
2.1 Appearance .....	9
2.2 LED Indicators .....	9
2.3 Ethernet Interfaces ETH1, ETH2 (X10, X11) .....	9
2.3.1 Function Description .....	9
2.3.2 Pin Definition .....	10
2.4 MVB Interface S1(X20, X21) .....	10
2.4.1 EMD Pin Definition .....	10
2.4.2 ESD+ Pin Definition .....	10
2.5 RS-232/422/485 Interface S3 (X3) .....	11
2.5.1 Function Description .....	11
2.5.2 Pin Definition .....	11
2.5.3 RS-485 Terminal Matching .....	12
2.6 CAN/RS-422/RS-485 Interface S4 (X4) .....	12
2.6.1 Function Description .....	12
2.6.2 Pin Definition .....	12
2.6.3 CAN bus Terminal Matching .....	12
2.6.4 RS-485 Terminal Matching .....	13
2.7 Power Interface (X5) .....	13
2.7.1 Function Description .....	13
2.7.2 Pin Definition .....	13
<b>3 Building Configuration Environment</b> .....	<b>14</b>
3.1 Connect Management Computer to MVB-TCMS .....	14
3.2 Get Configuration Management Software yacer-DMS .....	14
3.3 Run yacer-DMS software .....	14
3.4 Main Window of yacer-DMS .....	15
3.5 Statistical Report .....	15
3.5.1 Control Panel .....	15
3.5.2 Receive/Transmit Indication Panel .....	16
3.5.3 Information Panel .....	16
3.6 Configure Device .....	16
<b>4 Function and Configuration</b> .....	<b>18</b>
4.1 Ethernet Configuration .....	18

4.1.1 Ethernet Interface Working Mode .....	18
4.1.2 Enable Ethernet Switch .....	18
4.1.3 Dual IP Configuration .....	19
4.1.4 Default Gateway .....	19
4.2 Interface Configuration .....	20
4.2.1 Function Description .....	20
4.2.2 MVB Interface Configuration .....	20
4.2.3 Serial Port Configuration .....	21
4.2.4 MVB to Serial Configuration .....	24
4.3 UDP Configuration .....	25
4.3.1 Function Description .....	25
4.3.2 UDP to Interface .....	25
4.3.3 Interface to UDP .....	26
4.4 MVB-PD Configuration .....	27
4.4.1 Sink Port to Ethernet .....	28
4.4.2 Sink Port to Serial .....	28
4.5 TRDP-PD Configuration .....	28
4.5.1 Function Description .....	28
4.5.2 TRDP-PD Subscribe .....	29
4.5.3 TRDP-PD Publish .....	29
<b>5 System Maintenance .....</b>	<b>30</b>
5.1 Firmware Version Upgrade .....	30
5.1.1 Start Upgrade .....	30
5.1.2 Select Version File .....	30
5.1.3 Complete Upgrade .....	31
5.1.4 Confirm Upgrade .....	31
5.2 Reboot Device .....	32
5.3 Ping .....	32
<b>6 Mechanical Characteristics &amp; Installation .....</b>	<b>33</b>
<b>7 Verification and Debugging of MVB .....</b>	<b>34</b>
7.1 Auxiliary Equipment .....	34
7.2 Auxiliary Software .....	34
7.3 Debugging and Testing Scheme .....	34
<b>8 Software Development .....</b>	<b>35</b>
8.1 MVB Data Format Conversion .....	35
8.2 TRDP Data Format Conversion .....	35
8.3 CAN Data Format Conversion .....	35

# 1 Overview

## 1.1 Introduction

The Yacer MVB-TCMS TCN protocol converter provides 1x MVB interface, 2x 100M Ethernet interfaces and 2x extended interfaces to implement protocol conversion between MVB, serial port, CAN bus and Ethernet, and optionally supports TRDP protocol.

Industrial wide temperature, complete isolation and protection, compact size, suitable for train communication network.



## 1.2 Applications

- Protocol conversion between MVB and Ethernet interface;
- Port conversion between MVB and serial port;
- Interface conversion between serial port and Ethernet interface;
- Protocol conversion between CAN and Ethernet interface;
- Protocol conversion between TRDP and UDP;
- Protocol conversion between TRDP and serial port;
- Train Control and Management System (TCMS);
- Train Communication Network (TCN);

## 1.3 Features

- 1x MVB interface, optional ESD +, EMD media
- Compliance with IEC61375 standard;
- 2x 100M Ethernet interfaces, optional supporting TRDP protocol;
- X3 extended interface: Optional RS-232, RS-422 or RS-485 serial port;
- X4 extended interface: Optional RS-422, RS-485 serial port or CAN bus interface;
- Perfect isolation protection, industrial wide temperature.

## 1.4 Order Information

MVB-TCMS	-	M	3	5	U	-LV	
MVB Type:							
• EMD		M					
• ESD+		S					
X3 extended interface:							
• None			0				
• Full-duplex RS-232			3				
• Full-duplex RS-422			4				
• Half-duplex RS-485			5				
X4 extended interface:							
• None				0			
• Full-duplex RS-422				4			
• Half-duplex RS-485				5			
• CAN bus interface				6			
UDP/TRDP support:							
• Ethernet supports UDP protocol					U		
• Ethernet supports UDP, TRDP protocol					T		
Supply voltage range:							
• Nominal 24V, tolerance 9 ~ 36VDC						-LV	
• Nominal 36V, 48V, tolerance 18 ~ 75VDC						-MV	
• Nominal 72V, 96V, 110V, tolerance 40 ~ 160VDC						-HV	
MVB D-Sub Bolts:							
• M3 Bolts							<empty>
• UNC4-40 Bolts							-UNC

## 1.5 Function Blocks

The basic function blocks are shown in the following figure:

- X20, X21 are MVB dual line redundant interfaces S1;
- X3 is the extended interface S3, optional RS-232, RS-422 or RS-485;
- X4 is the extended interface S4, optional CAN, RS-422 or RS-485;
- ETH1, ETH2 are two 100M Ethernet ports, which are connected to connectors X10 and X11 respectively.
- X5 is the power connector.

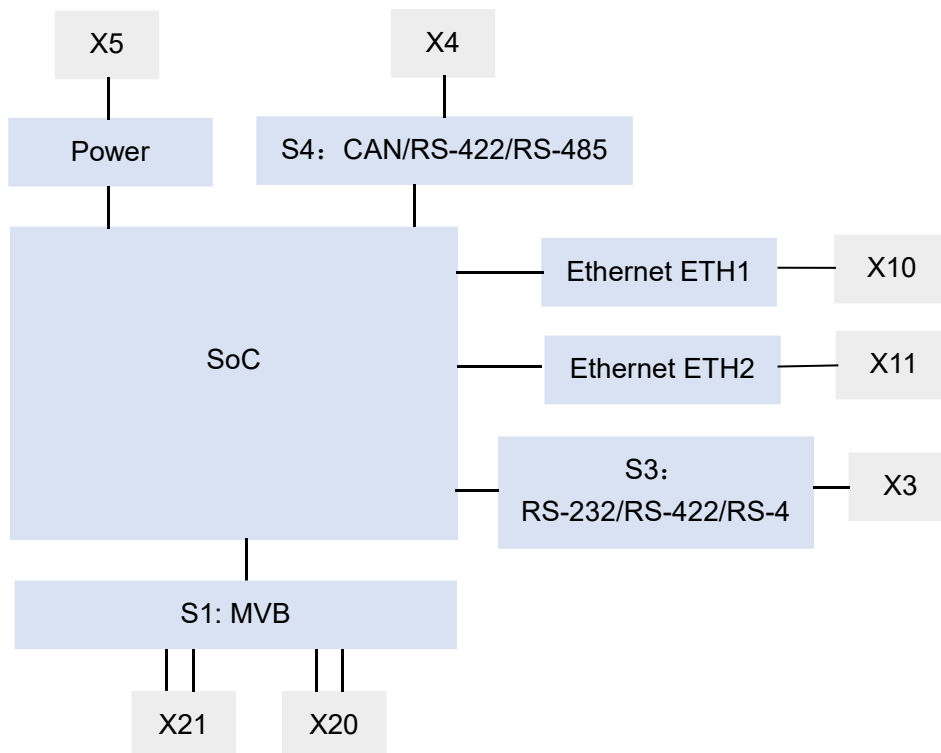

## 1.6 Technical Specifications

Item	Parameters	Details
MVB Interface S1	Connector	1x male D-Sub 9 (X20) + 1x female D-Sub 9 (X21)
	Media type	Optional EMD, ESD+
	Device class	Class 1
	Device capabilities	Device_Status, Process_Data(PD)
	Number of PD ports	1024
	Isolation	2.5 kVrms
Extended Interface S3	Connector	1x male D-Sub 9 (X3)
	Optional type	<ul style="list-style-type: none"> <li>● RS-232 full-duplex serial port</li> <li>● RS-422 full-duplex isolated serial port</li> <li>● RS-485 half-duplex isolated serial port</li> </ul>
	Baud rate	Asynchronous $\leq 1$ Mbps
	Isolation	2.5 kVrms
Extended Interface S4	Connector	1x male D-Sub 9 (X4)
	Optional type	<ul style="list-style-type: none"> <li>● CAN bus isolation interface (CAN2.0A, CAN2.0B, ISO 11898)</li> <li>● RS-422 full-duplex isolated serial port</li> <li>● RS-485 half-duplex isolated serial port</li> </ul>
	Baud rate	UART $\leq 1$ Mbps CAN: 50 Kbps ~ 1 Mbps
	Isolation	2.5 kVrms
Ethernet Interface	Connector	2x M12 with D-coding
	Function	Supporting Ethernet switching, dual-IP function
	Rate	100 Mbps
	Protocol	TCP/IP, optional supporting TRDP
	Programming interface	UDP Server, UDP Client Supporting Unicast/Multicast/Broadcast
	Isolation	1.5 kVrms



Item	Parameters	Details
Configuration Management	Configuration tool	yacer-DMS configuration management software
	Configuration interface	Ethernet Interface, optional serial port
Power Requirements	Power supply	LV: Nominal 24V, tolerance 9 ~ 36VDC MV: Nominal 36V, 48V, tolerance 18 ~ 75VDC HV: Nominal 72V, 96V, 110V, tolerance 40 ~ 160VDC
	Isolation protection	>1.5 kV, Anti-reverse protection
	Power consumption	< 3 W
	Power connector	3 pin connector with 5mm pitch (Phoenix Contact MSTB 2,5 / 3-GF or equivalent)
Mechanical Characteristics	Dimensions	H x W x D: 124 mm x 36 mm x 104 mm
	Weight	500g
Operating Environment	Operating temperature	-40 ~ +70°C
	Storage temperature	-40 ~ +85°C
	Operating humidity	5 ~ 95% RH (no condensation)

## 2 Hardware and Physical Interface

### 2.1 Appearance



### 2.2 LED Indicators

LED	Description
RUN	Running indicator, green light flashes during normal operation
ALARM	Alarm indicator, on when the device is not ready or fails, and constantly off during normal operation
MVB A	MVB interface A line transceiver instructions
MVB B	MVB interface B line transceiver instructions
X3	Extended interface S3 transceiver instructions
X4	Extended interface S4 transceiver instructions
LINK/ACT	Link/ACT indication of Ethernet interfaces

### 2.3 Ethernet Interfaces ETH1, ETH2 (X10, X11)

#### 2.3.1 Function Description

ETH1, ETH2 are two 10/100M Ethernet interfaces with connectors X10 and X11 as M12 (D-coding).

There are two working modes for the Ethernet interfaces:

- Ethernet switching mode: Enable the built-in Ethernet switching function;
- Dual IP mode: Each Ethernet interface has an independent IP address.

## 2.3.2 Pin Definition

X10, X11 Pin	Description
1	TD +
2	RD +
3	TD -
4	RD -



## 2.4 MVB Interface S1(X20, X21)

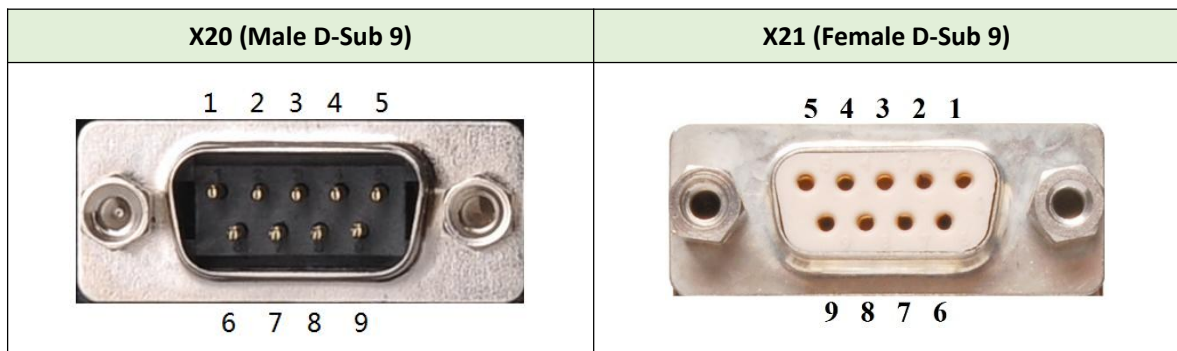

### 2.4.1 EMD Pin Definition

Pin	X20 (Male) Signal name	X21 (Female) Signal name	Description
1	A.Data_P		Line A positive ( + )
2	A.Data_N		Line A negative ( - )
3			
4	B.Data_P		Line B positive ( + )
5	B.Data_N		Line B negative ( + )
6	A.Term_P		Line A matching resistance positive ( + )
7	A.Term_N		Line A matching resistance negative ( - )
8	B.Term_P		Line B matching resistance positive ( + )
9	B.Term_N		Line B matching resistance negative ( - )

### 2.4.2 ESD+ Pin Definition

Pin	X20 (Male) Signal name	X21 (Female) Signal name	Description
1	A.Data_P		Line A positive ( + )
2	A.Data_N		Line A negative ( - )

Pin	X20 (Male) Signal name	X21 (Female) Signal name	Description
3			
4	B.Data_P		Line B positive ( + )
5	B.Data_N		Line B negative ( + )
6	A.Bus_GND		Line A ground
7	B.Bus_GND		Line B ground
8	A.Bus_5V_output		Line A power supply for terminal matching
9	B.Bus_5V_output		Line B power supply for terminal matching

## 2.5 RS-232/422/485 Interface S3 (X3)

### 2.5.1 Function Description

X3 is an extended serial port, users can choose one of the following types when ordering:

- RS-232 full-duplex;
- RS-422 full-duplex with isolation;
- RS-485 half-duplex with isolation.



### 2.5.2 Pin Definition

X3 uses male D-Sub 9 male connector, pin defined as follows:

Pin	RS-232 Full-duplex	RS-422 Full-duplex	RS-485 Half-duplex
1			
2	RxD		
3	TxD	ISO_GND	ISO_GND
4		TxD +	Data +
5	GND	TxD -	Data -
6			
7			
8		RxD +	Term +
9		RxD -	Term +

## 2.5.3 RS-485 Terminal Matching

In RS-485 mode, 8-9 short connection enable terminal matching, matching resistance is 120 ohms.

## 2.6 CAN/RS-422/RS-485 Interface S4 (X4)

### 2.6.1 Function Description

X4 is an extended interface, users can choose serial port or CAN bus interface when ordering. When the serial port is configured, one of the following configurations can be selected from the factory:

- RS-422: full-duplex with isolation;
- RS-485: half-duplex with isolation.



### 2.6.2 Pin Definition

S4 connector X4 uses male D-Sub 9 male connector, pin defined as follows:

Pin	CAN	RS-422 Full-duplex	RS-485 Half-duplex
1	Term +		
2	CAN_L		
3	ISO_GND	ISO_GND	ISO_GND
4		TxD +	Data +
5		TxD -	Data -
6	Term -		
7	CAN_H		
8		RxD +	Term +
9		RxD -	Term -

### 2.6.3 CAN bus Terminal Matching

In CAN working mode, 1-6 short connection enable terminal matching of CAN bus, matching resistance is 120 ohms.

## 2.6.4 RS-485 Terminal Matching

In RS-485 mode, 8-9 short connection enable terminal matching, matching resistance is 120 ohms.

## 2.7 Power Interface (X5)

### 2.7.1 Function Description

MVB-TCMS is powered by DC power supply, supports isolation protection and surge protection, and provides anti-inverse protection.

Depending on the factory configuration, the power input range is as follows:

Model	Nominal value	Minimum value	Maximum value
LV	24V	9V	36V
MV	36V、48V	18V	75V
HV	72V、96V、110V	40V	160V

### 2.7.2 Pin Definition

The X5 uses a 3-pos 5mm terminal connector (Phoenix Contact MSTB 2,5 / 3-GF compatible).

Pin	Signal name	Description
1	V +	Voltage +
2	CASE	Protection ground
3	V -	Voltage -



## 3 Building Configuration Environment

### 3.1 Connect Management Computer to MVB-TCMS

Connect the management computer with any Ethernet interface port of MVB-TCMS through network cable, and run yacer-DMS configuration management software on the computer to configure the parameters and monitor running status of MVB-TCMS.

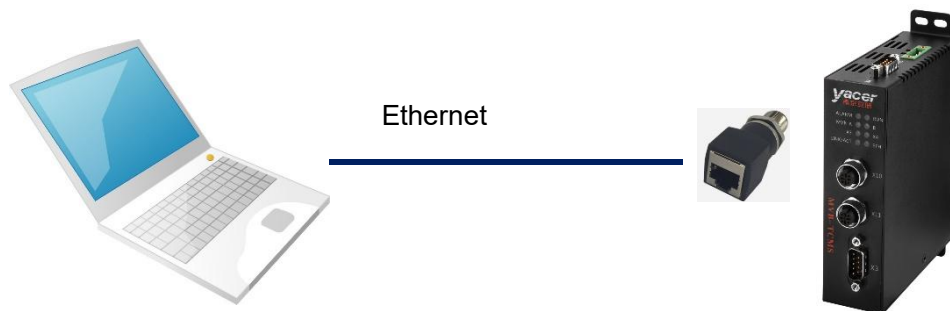

If S3 and S4 are serial ports, when configured as DMS-ISP mode, the computer serial port can be connected and configured and managed with yacer-DMS.

### 3.2 Get Configuration Management Software yacer-DMS

Users can obtain the compressed package yacer-DMS.zip of configuration management software through the following ways:

- “Softwares” directory of MVB-TCMS accompanied U-Disk;
- Official website of Yacer (<http://www.yacer.com.cn>) Software channel.

### 3.3 Run yacer-DMS software

The yacer-DMS is an installation free application software, unzip yacer-DMS.zip, enter the working directory and double click the file yacer-DMS.exe to run.

### 3.4 Main Window of yacer-DMS

The following figure is the main interface of the configuration management software, which can be divided into three parts:

- **Toolbar:** Functional operation buttons;
- **Device List:** Displaying the basic information and operation status of online devices;
- **Statistical Report:** Displaying the receive/transmit indication & statistics, and device details.

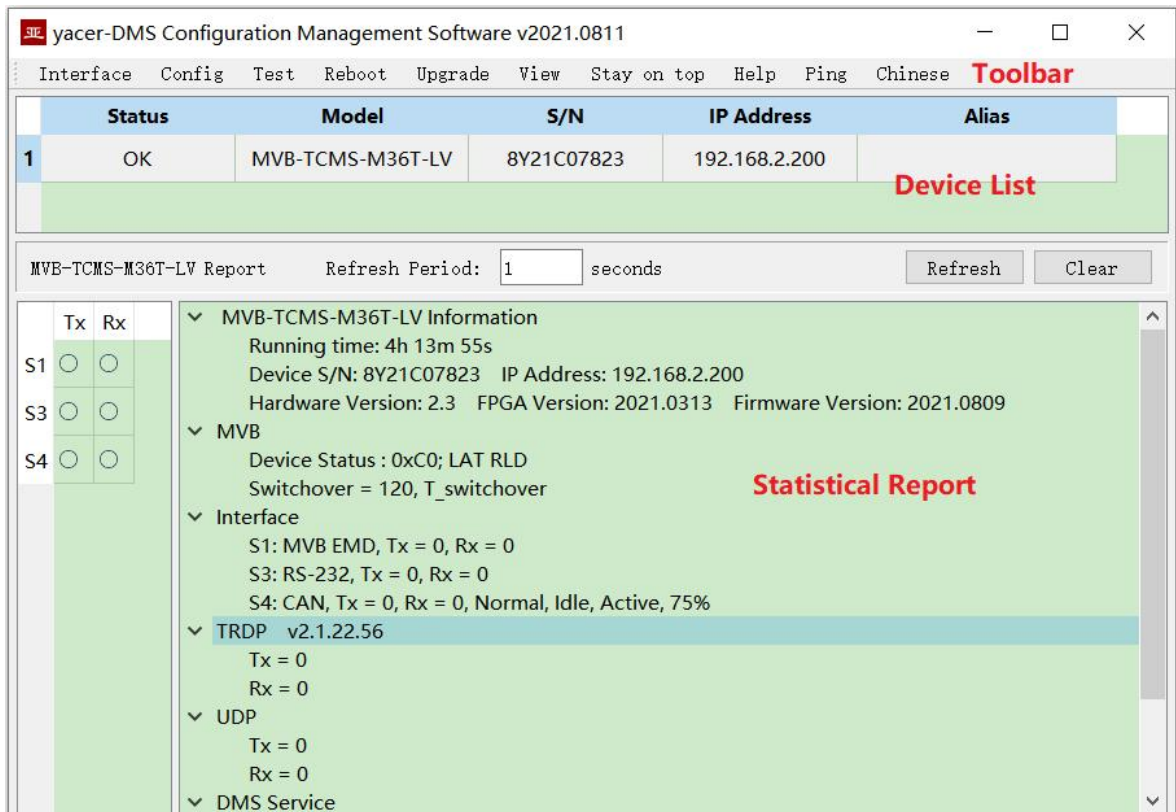

### 3.5 Statistical Report

The statistical report has three panels: control panel, receive/transmit indication panel and information panel.

#### 3.5.1 Control Panel

The statistics report is refreshed once per second, Click the “Clear” button to clear the statistics.

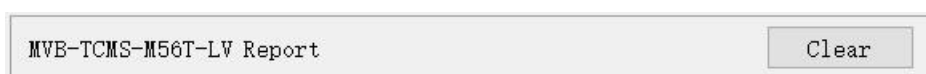



### 3.5.2 Receive/Transmit Indication Panel

- Tx: The interface sends a frame of data, corresponding Tx indicator blinks once;
- Rx: The interface receives a frame of data, corresponding Rx indicator blinks once.

	Tx	Rx	
S1	○	○	
S3	○	○	
S4	○	○	

### 3.5.3 Information Panel

The right side of the statistical report is the information panel, which can display the following contents:

- Device information: Running time, S/N number, version number;
- MVB: MVB bus status information;
- Interface: Receive/transmit statistics of MVB, Serial port, CAN and other interfaces;
- TRDP: Receive/transmit statistics of TRDP protocol;
- UDP: Receive/transmit statistics of UDP;
- DMS Service: DMS message receive/transmit statistics.

## 3.6 Configure Device

Click the “Config” button on the toolbar or double-click the selected device in the device list, yacer-DMS pops up the configuration dialog. According to the interface and function, the dialog divides the configuration items into several configuration pages.

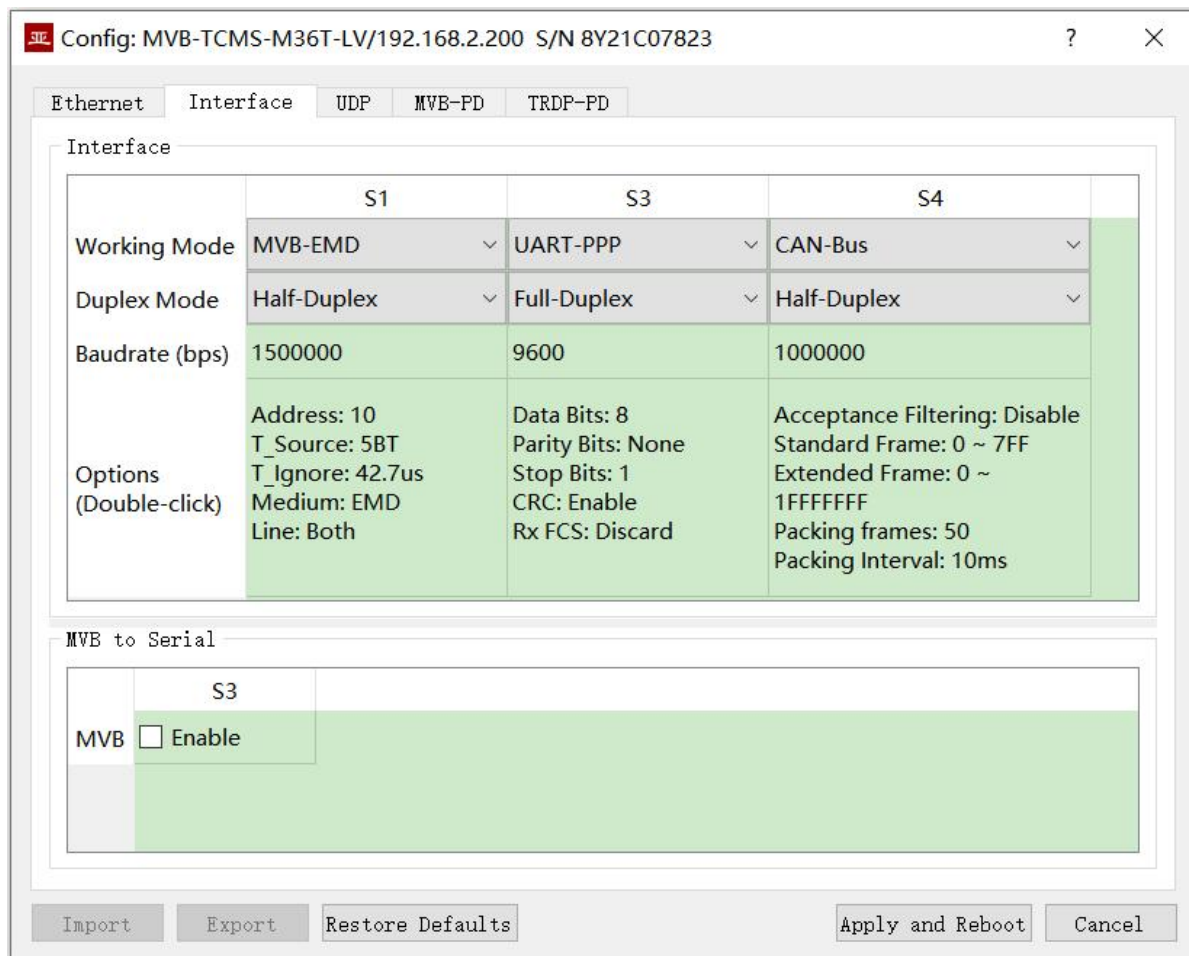

The bottom of the dialog box includes the following operation buttons:

Button	Function
	Open the configuration file, read the configuration parameters refresh the configuration dialog
	Export configuration parameters from the configuration dialog to a file for saving
	Refresh the configuration dialog with the factory paramters
	Write the configuration parameters in the dialog to the device, and restart the device to make the configuration take effect
	Cancel current configuration operation

## 4 Function and Configuration

### 4.1 Ethernet Configuration

#### 4.1.1 Ethernet Interface Working Mode

The Ethernet interface can be selected from two speed modes: Auto Negotiation and 100M Full-duplex.

The Ethernet interface that supports the TRDP protocol, whose speed mode is forced to 100M full-duplex.

Ethernet						
Interface						
UDP						
MVB-PD						
TRDP-PD						
<input type="checkbox"/> Enable Ethernet Switch						
	IP Address	Subnet Mask	Default Gateway	Speed	Protocol	
ETH1	192.168.2.200	255.255.255.0	0.0.0.0	100M Full-duplex	TRDP	
ETH2	192.168.3.200	255.255.255.0	0.0.0.0	Auto Negotiation	UDP	
				Auto Negotiation		
				100M Full-duplex		

#### 4.1.2 Enable Ethernet Switch

By default, check the “Enable ethernet switch” checkbox to enable the built-in Ethernet switch, to provide Ethernet switching function between ETH1 and ETH2.

<input checked="" type="checkbox"/> Enable ethernet switch						
	IP Address	Subnet Mask	Default Gateway	Speed		
ETH1	192.168.2.200	255.255.255.0	0.0.0.0	Auto Negotiation		

After enabling the Ethernet switching function, MVB-TCMS only has one IP address. The network functions are as follows:

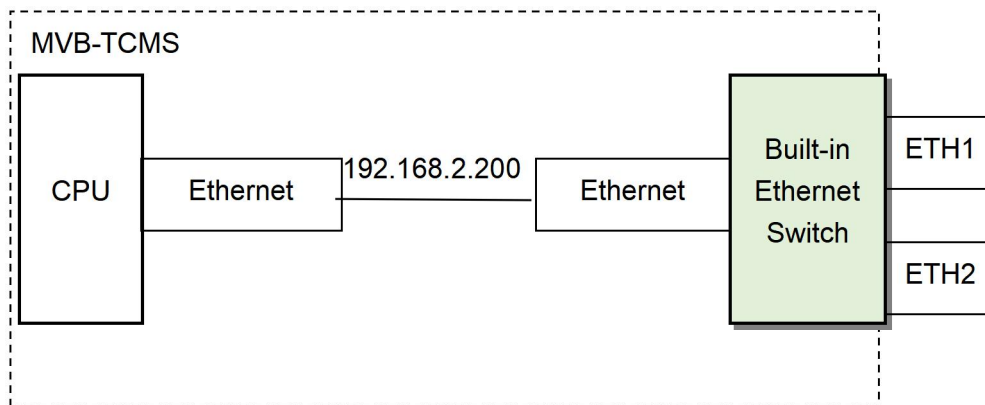

### 4.1.3 Dual IP Configuration

When the “Enable ethernet switch” checkbox is unchecked, ensure ETH1 and ETH2 are not on the same subnet for configuration as they have an independent IP address.

Enable ethernet switch

	IP Address	Subnet Mask	Default Gateway	Speed
ETH1	192.168.2.200	255.255.255.0	0.0.0.0	Auto Negotiation
ETH2	192.168.3.200	255.255.255.0	0.0.0.0	Auto Negotiation

With the dual-IP function figure as follows, the MVB-TCMS is equivalent to a computer equipped with two network cards.

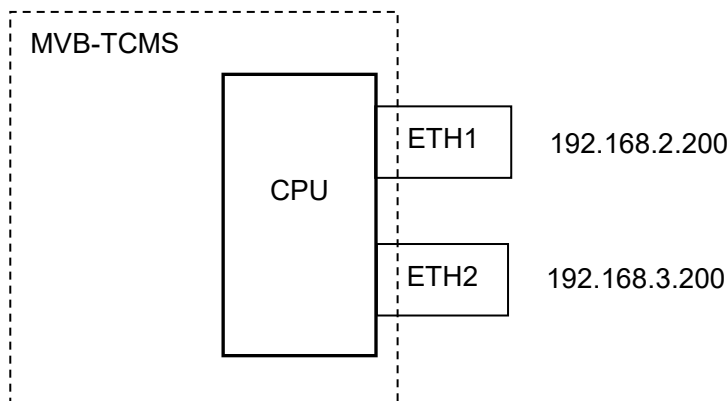

### 4.1.4 Default Gateway

By default, the default gateway is 0.0.0.0, representing that there is no gateway configuration. If MVB-TCMS needs to communicate with the host on other subnet, it must rely on an external router. At this time, the MVB-TCMS’s IP address must be on the same subnet with the IP address of the connected router port. Meanwhile, the IP address of router is set to the default gateway.

As shown below, the IP address of MVB-TCMS and remote PC is 192.168.2.200 and 192.168.5.100 respectively. As they do not belong to the same subnet, they must rely on the router for communication. MVB-TCMS and PC need to set the IP address of the connected router port to the default gateway of this device.

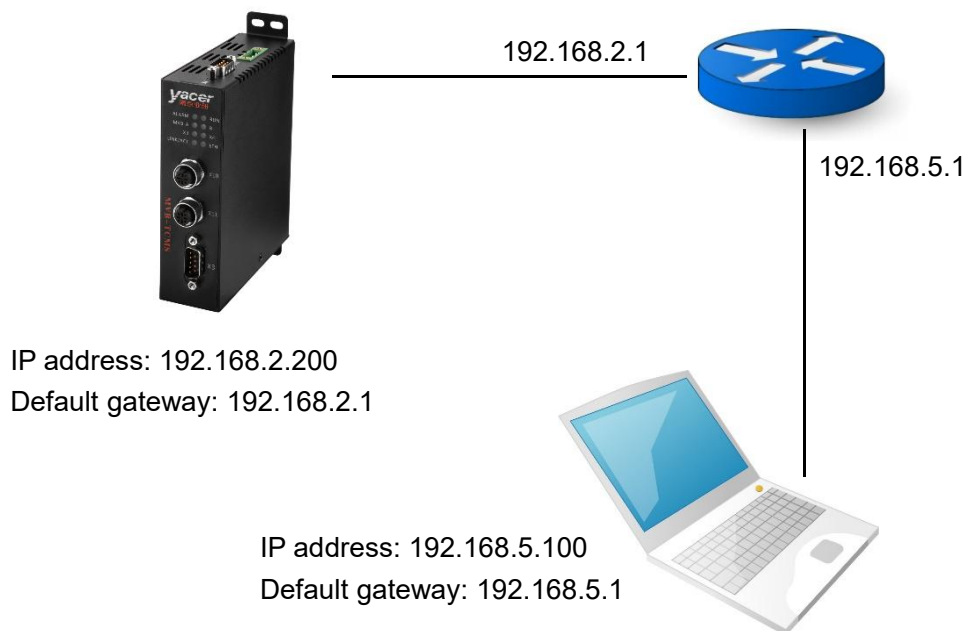

## 4.2 Interface Configuration

### 4.2.1 Function Description

This page is used to configure the working mode, duplex mode, baud rate and option parameters of the extended interface (MVB, serial port or CAN interface), and can configure the forwarding relationship between MVB and serial port.

### 4.2.2 MVB Interface Configuration

MVB interface S1 mode of work, duplex mode and baud rate set when factory, users do not need to modify. Double-click the advanced option cell to pop up the MVB parameter configuration dialog.

Device Address:	<input type="text" value="10"/>	0 - 4095
Media Type:	<input type="text" value="EMD"/>	
Line Mode:	<input type="text" value="Line Both"/>	
T_Source:	<input type="text" value="5"/>	ET (1ET = 0.667us)
T_Ignore:	<input type="text" value="0"/>	us (0 = 42.7us)

### 4.2.2.1 Device Address

Users configure device address in the range of 0 to 4095 according to field requirements.

### 4.2.2.2 Media Type

Media Type:	<input type="text" value="ESD"/>
-------------	----------------------------------

The media type defaults to the same as the physical layer.

MVB-TCMS allows the use to choose the media type of the logical layer for certain special occasions.

### 4.2.2.3 Line Mode

Line Mode:	<input type="text" value="Line A"/>
------------	-------------------------------------

Users can choose:

- Line Both: Dual line redundancy;
- Line A: Line A single line mode;
- Line B: Line B single line mode.

### 4.2.2.4 Other Parameters

Using default values, users do not modify or adjust as much as possible.

## 4.2.3 Serial Port Configuration

### 4.2.3.1 Working Mode

The extended interfaces S3 and S4 can be configured as serial ports when leaving the factory.

Users can select the desired working mode from the “working mode” combo box.

- UART: Universal asynchronous serial mode, similar to serial port on a universal computer;
- UART-PPP: Frame transmission on UART Interface using PPP protocol;
- DMS-ISP: yacer-DMS configuration management software can use this serial port for management.

Interface				
	S1	S3	S4	
Working Mode	MVB-EMD	UART-PPP	CAN-Bus	
Duplex Mode	Half-Duplex	UART	Half-Duplex	
Baudrate (bps)	1500000	UART-PPP	1000000	
		DMS-ISP		

After determining the working mode, the contents of the “Advanced Options” cell will be adjusted automatically according to the working mode.

If you need to further more configuration of working parameters for the selected working mode, double-click on the “Options” cell to pop up the parameter configuration dialog.

If the MVB interface and the extended serial port are configured to forward each other, the serial port default uses UART-PPP working mode. The UART-PPP working mode encapsulates MVB data and information into frames and transmits them on the asynchronous serial port.

### 4.2.3.2 UART-PPP Parameter Configuration

Since UART sends and receives character stream without head and tail, in order to transmit an MVB packet, a UART-PPP frame is constructed by adding 0x7E as the start and end flag at the beginning and end of the packet, and inserting a frame check sequence.

Data Bits:	8
Parity Bits:	None
Stop Bits:	1
	<input checked="" type="checkbox"/> CRC Enable
	<input type="checkbox"/> Forward received FCS field

### 4.2.3.3 UART Configuration

UART is a type of character stream communication. Data bits, check bits and stop bits define the basic working parameters of asynchronous serial port, which must be identical with the configuration of opposite device.

Generally, data bits are defined as 8 bits (1 byte), so that UART corresponds to the communication of byte streams.

Data Bits:	8	▼
Parity Bits:	None	▼
Stop Bits:	1	▼
Rx Packing Size:	128	bytes
Rx Packing Interval:	10	ms

When converting the byte stream of UART into UDP message, if every byte is converted into a UDP message for transmission, the overhead is too large and the efficiency is too low.

In order to improve the efficiency, MVB-TCMS will buffer the received byte stream, and then send out a UDP message composed of several buffered bytes. This process is called packing.

Packing is controlled by two parameters, which are called Packing Size & Packing interval.

#### 4.2.3.3.1 Packing Size

For example, if the Packing Size is set to 128 bytes, then when UART receives 128 bytes, a packet will be formed for forwarding.

Rx Packing Size:	128	bytes
------------------	-----	-------

#### 4.2.3.3.2 Packing Interval

For example, the above example sets the Packing Interval to 10ms. If the UART does not receive new data after 10ms, the data in the buffer will be forwarded as a packet regardless of whether 128 bytes are received.

Rx Packing Interval:	10	ms
----------------------	----	----

### 4.2.3.4 CAN Interface Configuration

X4 can be selected as CAN bus interface in the factory, and the configuration is as follows:

	<input type="checkbox"/> Acceptance Filtering	
Standard Frame IDmin	0	(Hex)
Standard Frame IDmax	7FF	(Hex)
Extended Frame IDmin	0	(Hex)
Extended Frame IDmax	1FFFFFFF	(Hex)
Rx Packing Frame Number:	50	
Rx Packing Interval:	10	ms

Because the CAN frame is very short, if each CAN frame is converted into a UDP message for transmission, the overhead is too large and the efficiency is too low.

In order to improve the efficiency, MVB-TCMS buffers the received can frames, and then forwards the buffered CAN frames into a packet, which is called packing.



Packing is controlled by two parameters, which are called Packing Frame Number & Packing interval.

#### 4.2.3.4.1 Packing Frame Number

The maximum Packing Frame Number is 50.

Rx Packing Frame Number:

As shown in the figure above, the Packing Frame Number is 50. When MVB-TCMS receives 50 CAN frames, it is assembled into a data packet for forwarding.

#### 4.2.3.4.2 Packing Interval

As the above example sets the packet splitting interval to 10ms, if no new CAN frame is received for more than 10ms, the CAN frames in the buffer will be composed into one packet for forwarding, regardless of whether 50 frames are received or not.

Rx Packing Interval:  ms

#### 4.2.3.4.3 Acceptance Filtering

The acceptance filtering allows users to set the frame ID range that is allowed to be received.

### 4.2.4 MVB to Serial Configuration

As shown in the figure below, if the extended interface is a serial port, the protocol conversion between MVB and serial port can be realized by checking "Enable".

If the serial port and MVB interface establish forwarding relationship, its working mode must be set to UART-PPP mode.

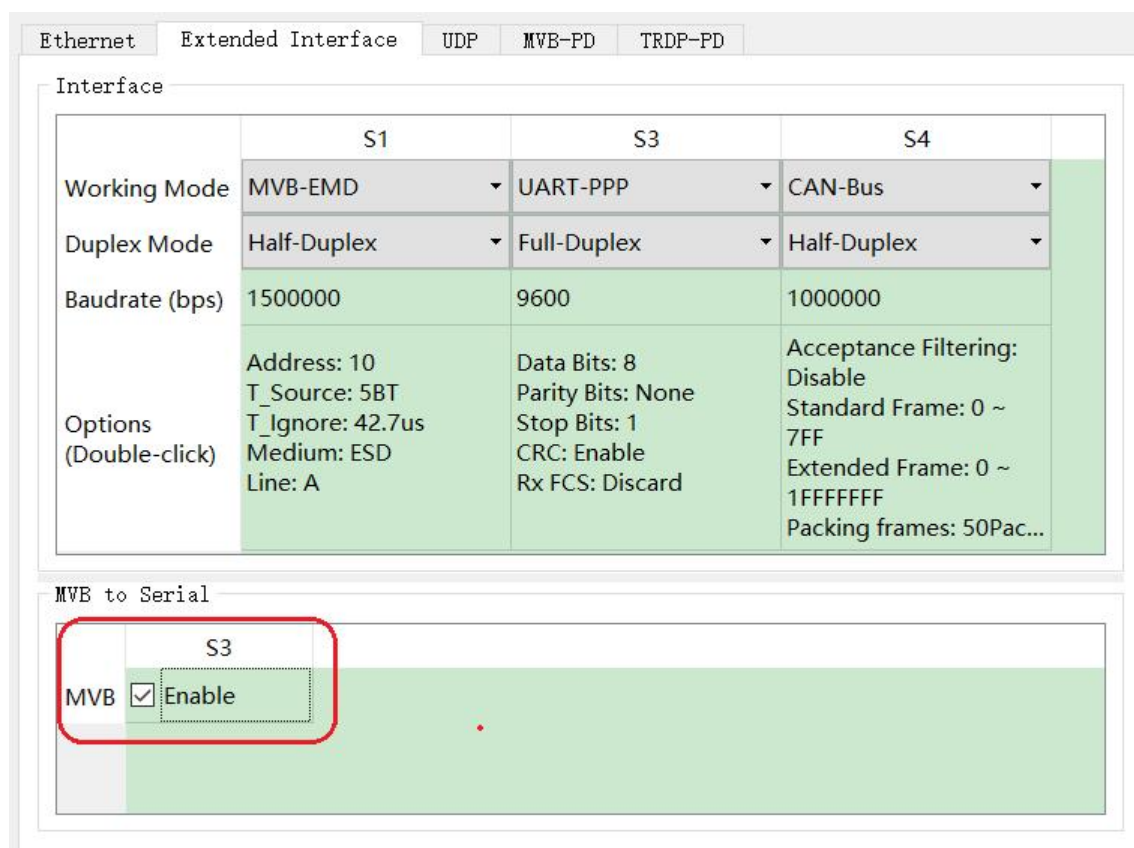

## 4.3 UDP Configuration

### 4.3.1 Function Description

This configuration page implements the following configuration:

- UDP to interface: Configure UDP packets received by Ethernet to be forwarded to MVB, serial port or CAN port;
- Interface to UDP: Configure data received by MVB, serial port or CAN port to Ethernet.

### 4.3.2 UDP to Interface

When MVB-TCMS configures the source port of MVB process data, it can receive UDP packets containing the frame data of the source port from Ethernet, and then refresh the data buffer of PD port. When the MVB interface receives the process data request from the master station, the MVB-TCMS automatically sends the process data response with the latest data content.

MVB-TCMS can also receive UDP messages from the remote, convert them into UART data or CAN frame according to the configuration, and send it out from the serial port or CAN port.

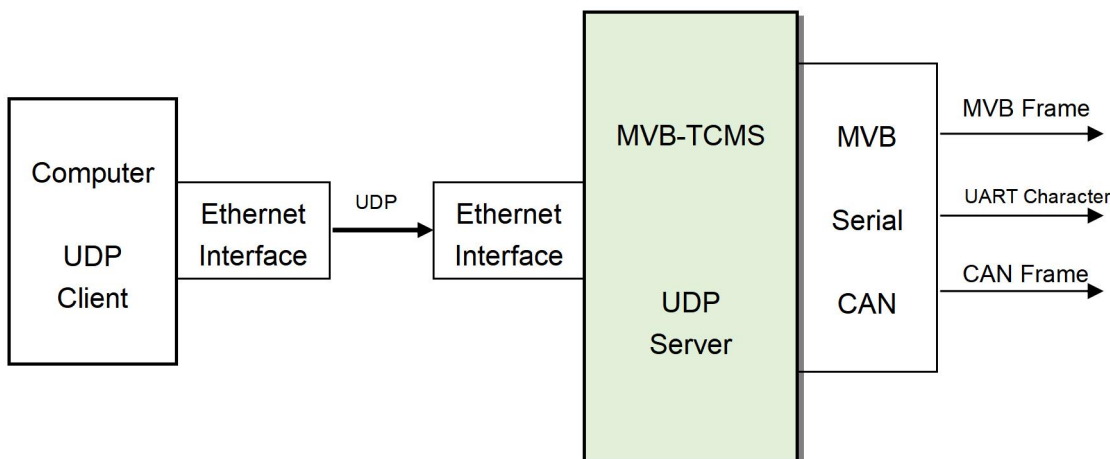

Click the right-click menu of forwarding table can add or remove forwarding entries and establish multiple forwarding combinations.

UDP to Extended Interface

	UDP Rx Port	UDP Rx Multicast	Forward to Interface
1	8000	224.9.9.9	S1
2	9000		S2

Add  
Remove

If you want to receive multicast messages, you must fill in a valid multicast address in the 'UDP receive multicast address' table. If only unicast or broadcast messages are received, the form will not be filled in or filled in with 0.

### 4.3.3 Interface to UDP

When MVB-TCMS is configured with the sink port of process data, it can receive the frame data of PD port from MVB bus, then convert it into UDP message and forward it to the destination computer through Ethernet interface.

At the same time, MVB-TCMS can also receive UART strings and subcontract them through serial ports, receive CAN frames and group packets through CAN ports, convert the above data frames or packets to UDP packets, and then send them to remote devices through Ethernet ports according to configuration.

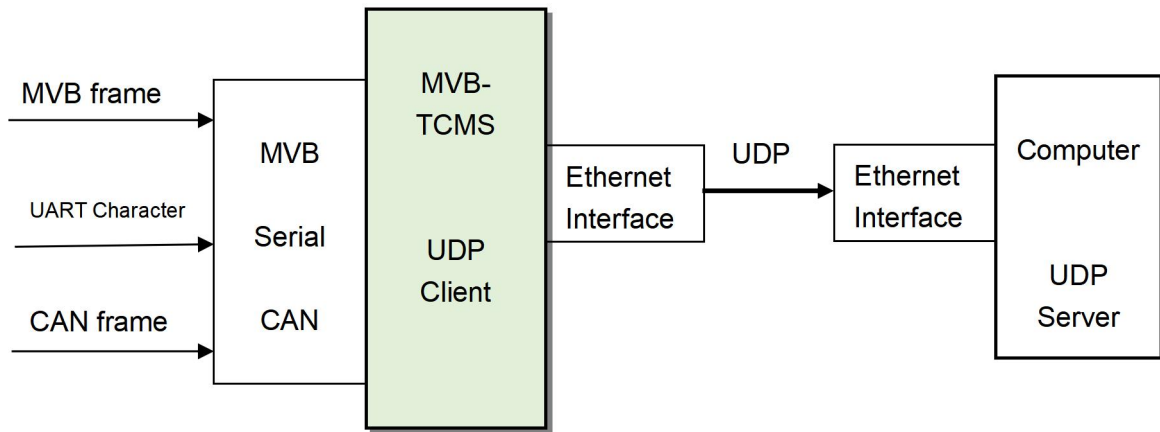

Click the right-click menu of forwarding table can add or remove forwarding entries and establish multiple forwarding combinations.

Extended Interface to UDP

	Rx from Interface	UDP Tx Destination IP	UDP Tx Destination Port
1	S1	192.168.2.80	8000
2	S3	224.9.9.9	9000

According to the application requirements, "UDP Tx Destination IP" can be unicast, multicast or broadcast address.

If the Ethernet of MVB-TCMS is configured with dual IPs, multicast and whole network broadcast messages will be sent to two IP subnets at the same time.

## 4.4 MVB-PD Configuration

Click the right-click menu of MVB table can add or remove PD port configuration and establish up to 1024 PD port configurations.

MVB

	PD Port Type	PD Port	Port Size
1	<input type="radio"/> Sink Port	500	2 bytes
2	<input type="radio"/> Sink Port	800	16 bytes
3	<input checked="" type="radio"/> Source Port	1200	32 bytes
4	<input checked="" type="radio"/> Source Port	2800	32 bytes

2 bytes  
 4 bytes  
 8 bytes  
 16 bytes  
 32 bytes

Each PD port entry includes the following parameters:

- PD Port Type: Select Sink port or Source port;
- PD Port: Set port number 0 ~ 4095;
- Port Size: 2, 4, 8, 16, 32 bytes correspond to 0 ~ 4 of fcode;

### 4.4.1 Sink Port to Ethernet

The PD sink port of MVB interface and the forwarding configuration of Ethernet are created in the 'Extended Interface to UDP' table of the 'UDP' configuration page.

When the MVB (S1) to UDP entry is configured, the MVB-TCMS forwards the received PD sink port data to the destination IP in real time.

Interface to UDP			
	Rx from Interface	UDP Tx Destination IP	UDP Tx Destination Port
1	S1	192.168.2.80	8000

### 4.4.2 Sink Port to Serial

The PD sink port of MVB interface and the forwarding configuration of serial port are created in the 'MVB to Serial' table of the 'Extended Interface' configuration page.

If the serial port is in full-duplex mode, MVB-TCMS forwards the received PD sink port data to the serial port in real time.

If the serial port is in half-duplex mode, after MVB-TCMS receives the PD sink port data, it only flushes the local data buffer and does not actively send data to the serial port. When the MVB-TCMS receives the MVB PD data pull command from the serial port, it immediately forwards the PD data in the data buffer to the serial port. This mode is called PULL mode, which is used to avoid sending conflict between two parties.

MVB to Serial		
	S3	S4
MVB	<input checked="" type="checkbox"/> Enable	<input type="checkbox"/> Enable

## 4.5 TRDP-PD Configuration

### 4.5.1 Function Description

This configuration page implements the following configuration:

- TRDP-PD Subscription: configure the parameters of subscription PD and the forwarding method of received PD data;
- TRDP-PD Publish: configure the parameters of publish PD and the source of PD data.

## 4.5.2 TRDP-PD Subscribe

MVB-TCMS receives the subscribed PD data through Ethernet interface and can choose to send it to the host computer through S1 ~ S4 interfaces or UDP.

COMID less than 1000 is reserved for the system, users must choose 1000 or more COMID.

TRDP PD Subscribe

	TRDP Rx COMID	TRDP Rx Multicast
1	1000	0.0.0.0
2	2000	224.10.10.10

Data Forward to

Dest IP Address:

Dest UDP Port:

Dest Serial:  S1  S2  S3  S4

As shown above, the subscription TRDP PD data is forwarded to the serial port S3 and the host with the destination IP of 192.168.2.80, where COMID 2000 is received through multicast.

When the destination IP or destination UDP port is configured to 0, the TRDP PD data is only forwarded from the selected serial port.

## 4.5.3 TRDP-PD Publish

MVB-TCMS receives the data to be published through UDP or other interfaces, and then sends them to the destination IP at the configured sending interval.

TRDP PD Publish

Data Receive from

Rx UDP Port:

Rx Multicast:

Rx Serial:  S1  S2  S3  S4

	TRDP Tx COMID	TRDP Tx Interval(ms)	TRDP Tx Destination IP
1	4000	100	192.168.2.80
2	5000	200	224.20.20.20

## 5 System Maintenance

### 5.1 Firmware Version Upgrade

#### 5.1.1 Start Upgrade

Click the “Upgrade” button on the toolbar to pop up the version upgrade dialog, and then click the “Start” button.

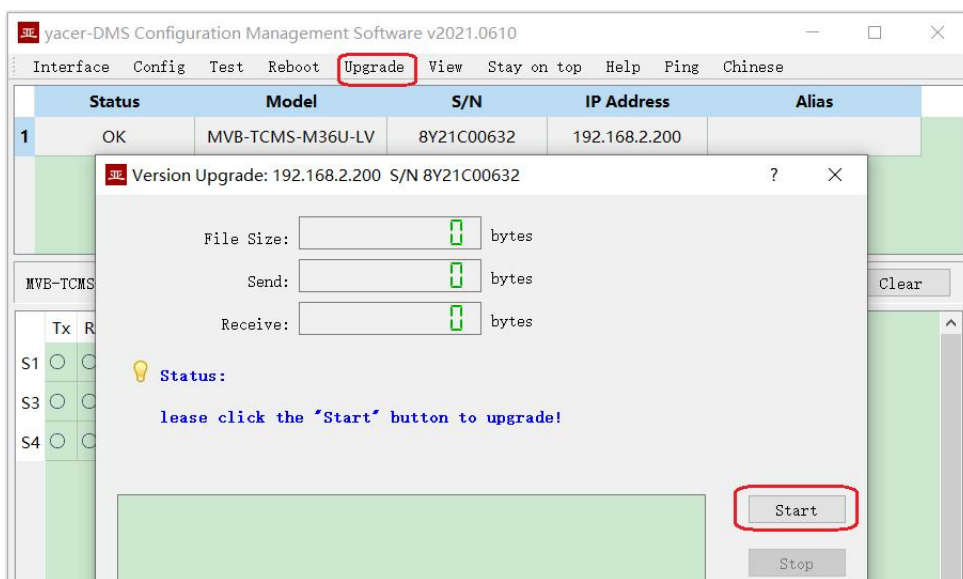

#### 5.1.2 Select Version File

Pop up the “Select version file” dialog, and find the folder where the latest firmware version is stored, select the corresponding file, and click “Open” to start the update.

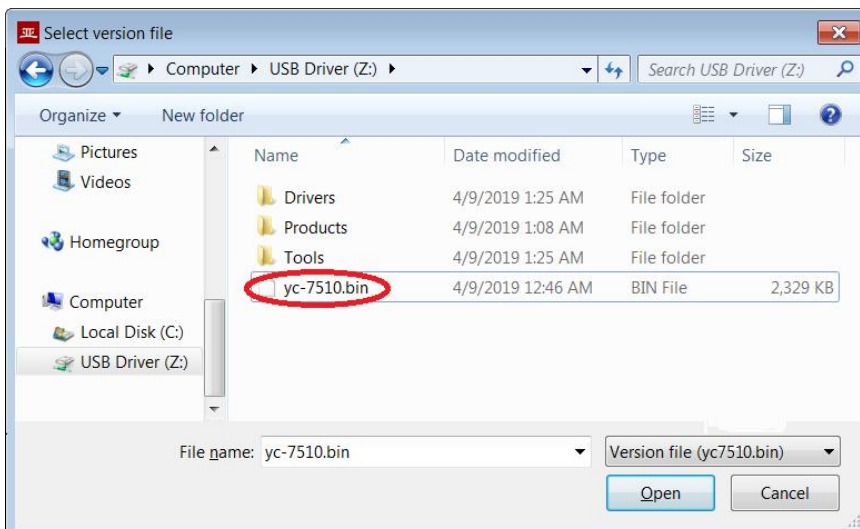

### 5.1.3 Complete Upgrade

When the page displays “Version upgrade complete” status, it indicates that the version upgrade is completed.

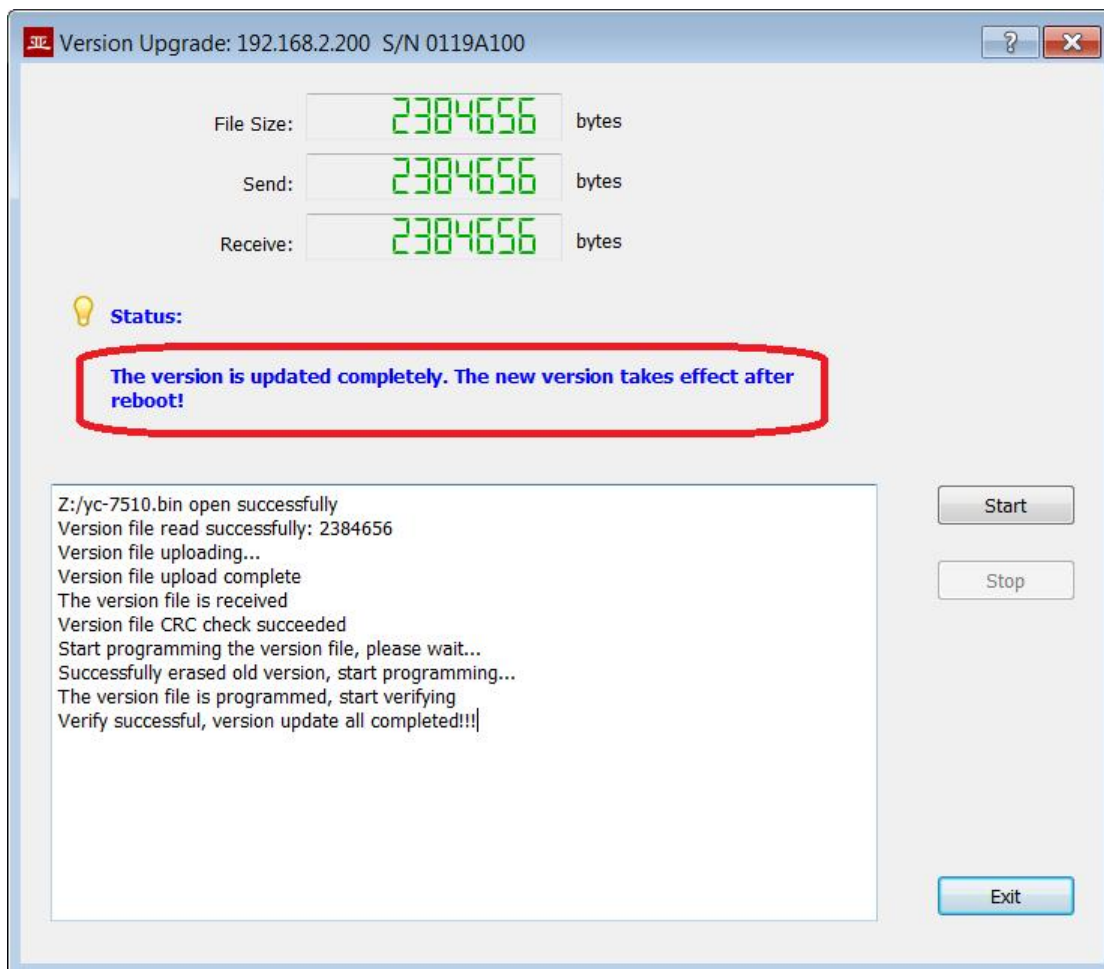

### 5.1.4 Confirm Upgrade

After the upgrade is completed, power up the device again, observe the version information in the statistical report, and determine whether the new version is successfully updated by the version date.





## 5.2 Reboot Device

Click the “Reboot” button on the toolbar to pop up the device reboot dialog, and then click the “Reboot” button to reboot the device.

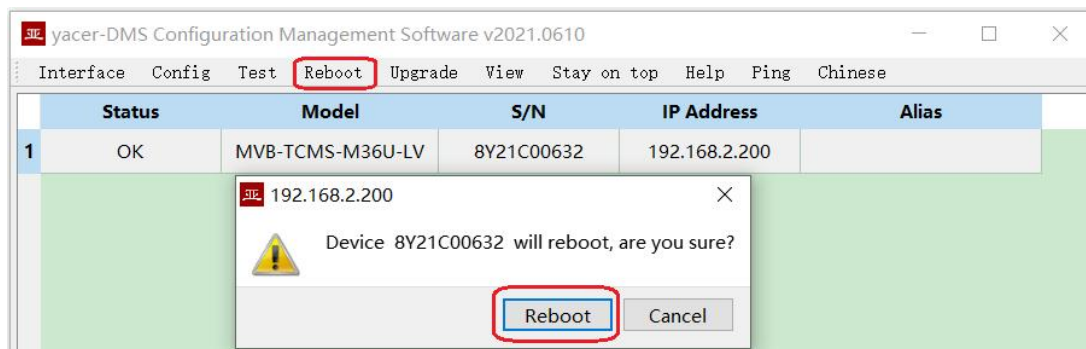

## 5.3 Ping

By clicking the "Ping" button on the toolbar, DMS automatically starts the ping command on the selected device to check whether the network connection between the configuration management computer and MVB-TCMS is working properly.

Before executing the Ping command, first make sure that the IP addresses of the computer and MVB-TCMS are in the same subnet.

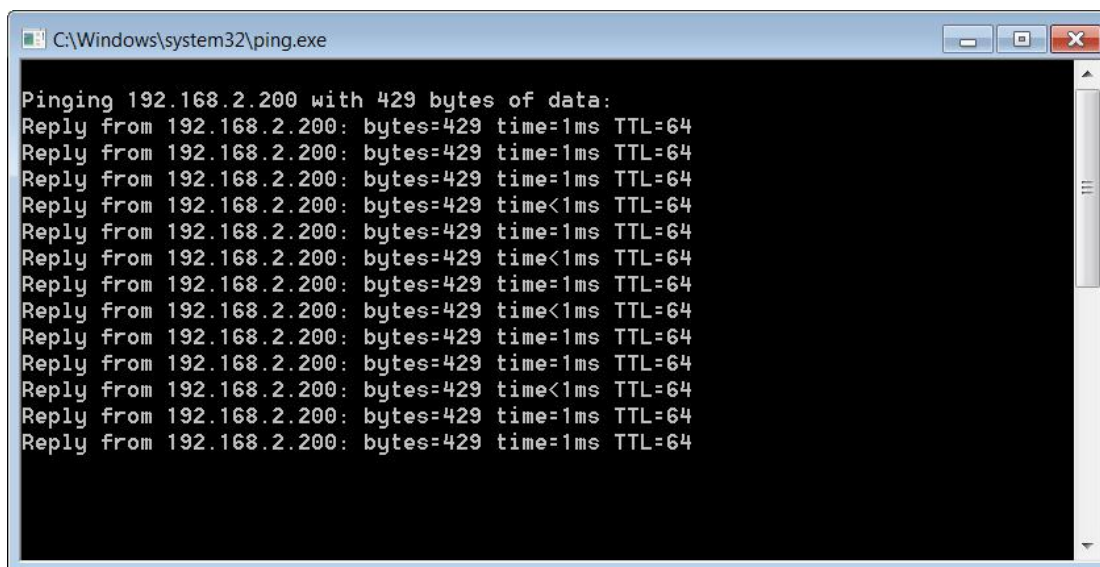

## 6 Mechanical Characteristics & Installation

The material of the housing shell is stainless steel. The thickness of the sheet metal is 1mm.

Dimensions (Height x Width x Depth) = 124 x 36 x 104mm.

MVB-TCMS can be mounted directly using four M4 Screws.

Mounting hole diameter = 4.4mm.

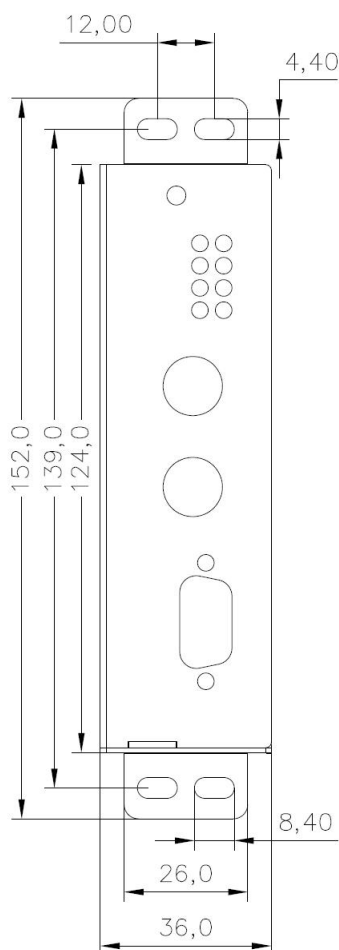

## 7 Verification and Debugging of MVB

### 7.1 Auxiliary Equipment

- Yacer MVB-Analyzer;
- Computer;
- YC9T straight-through cable.

### 7.2 Auxiliary Software

The following software can be obtained by MVB-TCMS attached U-Disk or accessing <http://www.yacer.com.cn> 'Software' channel:

- *yacer-DMS* configuration management software;
- *MVB-Monitor* monitoring and analysis software;
- *MVB-UDP* debugging assistant.

### 7.3 Debugging and Testing Scheme

MVB-TCMS realizes MVB bus interconnection through YC9T cable and MVB-Analyzer, and computers, MVB-TCMS and MVB-Analyzer realize Ethernet interconnection through switches.

The MVB-Monitor software running on the computer can control the MVB-Analyzer to simulate the host, so as to realize the data transceiver of MVB interface of MVB-TCMS.

At the same time, the MVB-UDP debugging assistant software is running on the computer to simulate the communication between the host computer and the MVB-TCMS Ethernet interface.

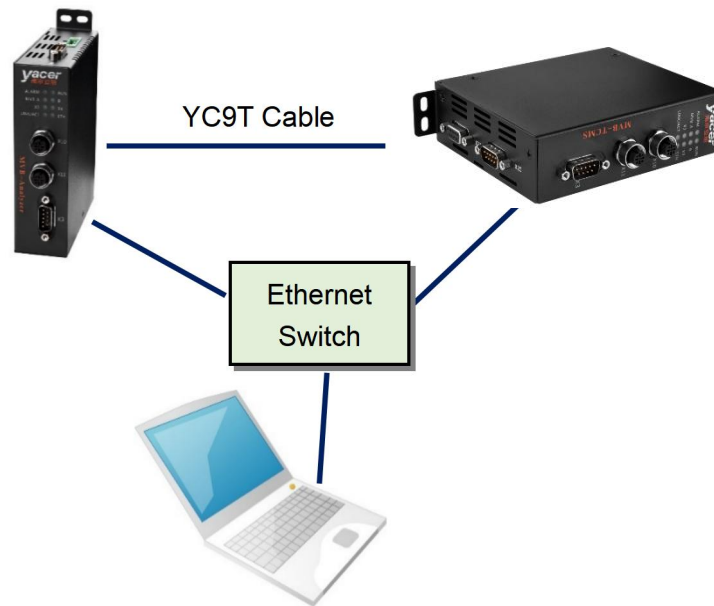

## 8 Software Development

### 8.1 MVB Data Format Conversion

See *TCN-PACKET\_Programming\_Manual.pdf*.

### 8.2 TRDP Data Format Conversion

See *TCN-PACKET\_Programming\_Manual.pdf*.

### 8.3 CAN Data Format Conversion

See *CAN-UDP\_Programming\_Manual.pdf*.

## About the Manual

- The manual is for reference only. If there is inconsistency between the manual and the actual product, the actual product shall prevail.
- We are not liable for any loss caused by the operations that do not comply with the manual.
- All the designs and software are subject to change without prior written notice. The product updates might cause some differences between the actual product and the manual. Please contact the customer service for the latest program and supplementary documentation.
- There still might be deviation in technical data, functions and operations description, or errors in print. If there is any doubt or dispute, we reserve the right of final explanation.
- Upgrade the reader software or try other mainstream reader software if the manual (in PDF format) cannot be opened.
- Please visit our website, contact the supplier or customer service if there is any problem occurring when using the device.
- If there is any uncertainty or controversy, we reserve the right of final explanation.